

3

3

|      |    |     |
|------|----|-----|
| K302 | 1  | K41 |
| K202 | 2  | K42 |
| K304 | WH | K44 |
| K204 | BN | K45 |
| K104 | GN | K46 |
| K205 | YE | K43 |

|           |            |       |  |  |            |  |            |
|-----------|------------|-------|--|--|------------|--|------------|
| Ændringer |            |       | Produkt  |  | Dato       |  | Målforhold |
| Nr.       | Dato       | Sign. | RCL 5100   |  | 10.03.1997 |  |            |
| A         | 10.03.1997 | MBJ   | Emne<br>ECT 5020   |  | Sign.      |  | 70 20 002  |
| B         | 22.08.2005 | JMO   |  |  | Erstatter  |  |            |
| C         | 07.12.2005 | BWK   |  |  | Tegn nr.   |  |            |
|           |            |       |  <b>Højbjerg Maskinfabrik <math>\frac{a}{s}</math></b><br>Oddervej 200 - DK-8270 Højbjerg |  | Erstat af  |  |            |
|           |            |       |  |  |            |  |            |

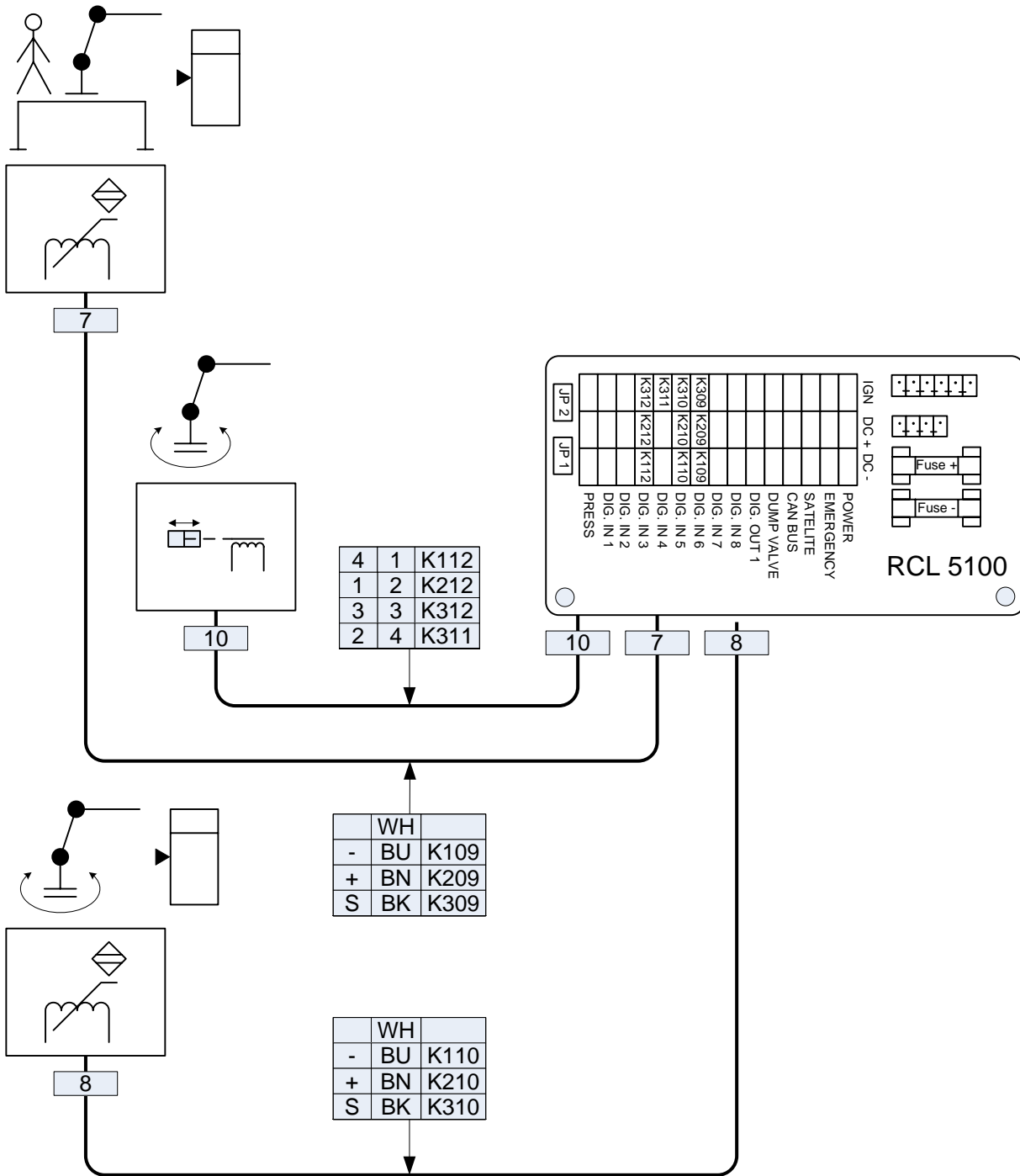

|   |   |      |
|---|---|------|
| 4 | 1 | K112 |
| 1 | 2 | K212 |
| 3 | 3 | K312 |
| 2 | 4 | K311 |

|   |    |      |
|---|----|------|
|   | WH |      |
| - | BU | K109 |
| + | BN | K209 |
| S | BK | K309 |

|   |    |      |
|---|----|------|
|   | WH |      |
| - | BU | K110 |
| + | BN | K210 |
| S | BK | K310 |

| Ændringer |            |      |
|-----------|------------|------|
| Nr.       | Dato       | Sign |
| A         | 03.02.1995 | MBJ  |
| B         | 25.08.2005 | BWK  |
| C         | 02.12.2005 | BWK  |
|           |            |      |
|           |            |      |
|           |            |      |

|         |  |
|---------|--|
| Produkt | <b>RCL 5100</b>  |
| Emne    | <b>HS Stop</b>   |
|         | <b>Højbjerg Maskinfabrik <sup>a</sup>/<sub>s</sub></b> |
|         | Oddervej 200 - DK-8270 Højbjerg                        |

|           |                   |                  |
|-----------|-------------------|------------------|
| Dato      | <b>03.02.1995</b> | Målforhold       |
| Sign.     | <b>MBJ</b>        |                  |
| Erstatter |                   | <b>70 20 005</b> |
| Tegn nr.  |                   |                  |
| Erstat af |                   |                  |

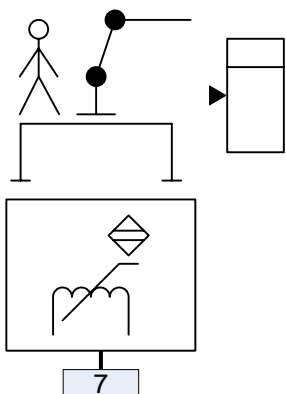

7

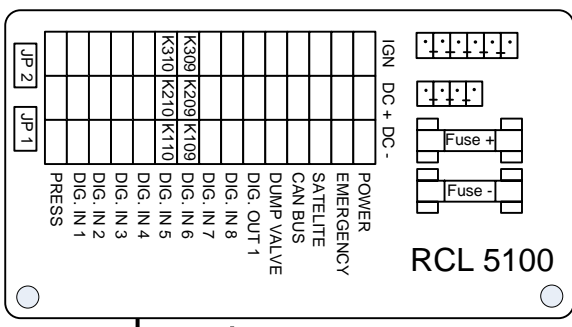

7

8

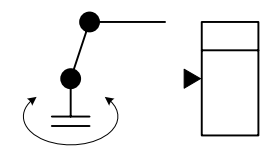

|   |    |      |
|---|----|------|
|   | WH |      |
| - | BU | K109 |
| + | BN | K209 |
| S | BK | K309 |

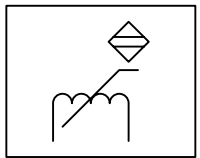

8

|   |    |      |
|---|----|------|
|   | WH |      |
| - | BU | K110 |
| + | BN | K210 |
| S | BK | K310 |

| Ændringer |            |      |
|-----------|------------|------|
| Nr.       | Dato       | Sign |
| A         | 03.02.1995 | MBJ  |
| B         | 02.12.2005 | BWK  |
|           |            |      |
|           |            |      |
|           |            |      |
|           |            |      |

Produkt **RCL 5100**

Emne **HS Advarsel**



**Højbjerg Maskinfabrik a/s**  
Oddervej 200 - DK-8270 Højbjerg

|           |                   |                  |
|-----------|-------------------|------------------|
| Dato      | <b>03.02.1995</b> | Målforhold       |
| Sign.     | <b>MBJ</b>        |                  |
| Erstatter |                   | <b>70 20 006</b> |
| Tegn nr.  |                   |                  |
| Erstat af |                   |                  |

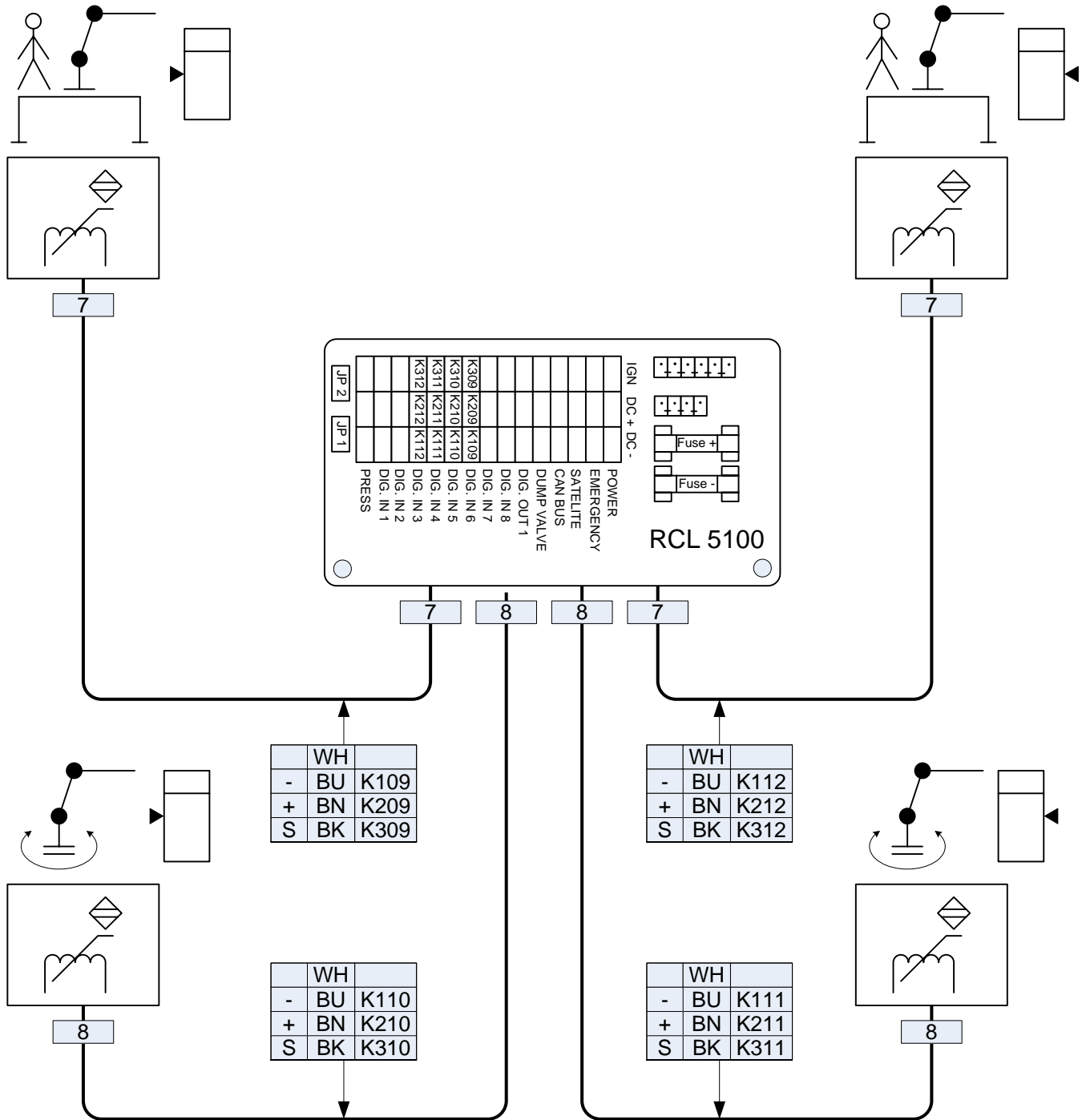

|           |            |      |  |  |            |  |            |  |
|-----------|------------|------|--|--|------------|--|------------|--|
| Ændringer |            |      | Produkt  |  | Dato       |  | Målforhold |  |
| Nr.       | Dato       | Sign | RCL 5100   |  | 29.03.2004 |  |            |  |
| A         | 29.03.2004 | PHH  |  |  | Sign.      |  | PHH        |  |
| B         | 08.12.2005 | BWK  | Emne   |  | Erstatter  |  |            |  |
|           |            |      | HS Dobbelt   |  | Tegn nr.   |  | 70 20 007  |  |
|           |            |      |  <b>Højbjerg Maskinfabrik <math>\frac{a}{s}</math></b><br>Oddervej 200 - DK-8270 Højbjerg |  | Erstat af  |  |            |  |
|           |            |      |  |  |            |  |            |  |

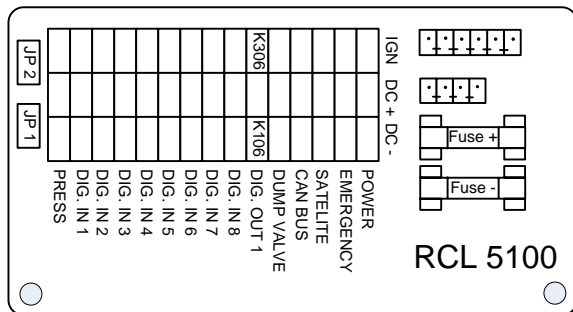

4

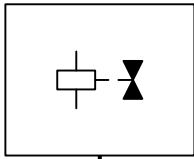

4

|      |   |   |
|------|---|---|
| K306 | 1 | 1 |
| K106 | 2 | 2 |

|           |            |       |   |  |                   |  |            |
|-----------|------------|-------|---|--|-------------------|--|------------|
| Ændringer |            |       | Produkt   |  | Dato              |  | Målforhold |
| Nr.       | Dato       | Sign. | RCL 5100  |  | 06.02.1997        |  |            |
| A         | 06.02.1997 | MBJ   | Emne  |  | Sign.             |  | Erstatter  |
| B         | 06.12.2005 | BWK   |   |  | 2-kreds hydraulik |  |            |
|           |            |       |  <b>Højbjerg Maskinfabrik <sup>2</sup>/<sub>5</sub></b><br>Oddervej 200 - DK-8270 Højbjerg |  | Tegn nr.          |  | 70 20 008  |
|           |            |       |   |  | Erstat af         |  |            |

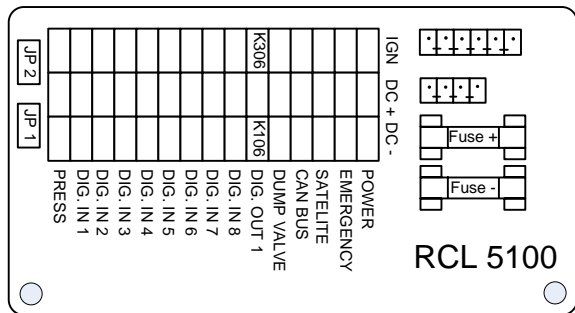

6

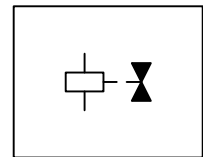

6

|      |   |   |
|------|---|---|
| K306 | 1 | 1 |
| K106 | 2 | 2 |

|           |            |       |  |  |            |  |            |
|-----------|------------|-------|--|--|------------|--|------------|
| Ændringer |            |       | Produkt  |  | Dato       |  | Målforhold |
| Nr.       | Dato       | Sign. | RCL 5100   |  | 05.07.1997 |  |            |
| A         | 05.07.1997 | MBJ   | Emne   |  | Sign.      |  | 70 20 009  |
| B         | 08.12.2005 | BWK   |  |  | HDL 2      |  |            |
|           |            |       |  <b>Højbjerg Maskinfabrik <sup>a/s</sup></b><br>Oddervej 200 - DK-8270 Højbjerg |  | Tegn nr.   |  | Erstat af  |
|           |            |       |  |  |            |  |            |

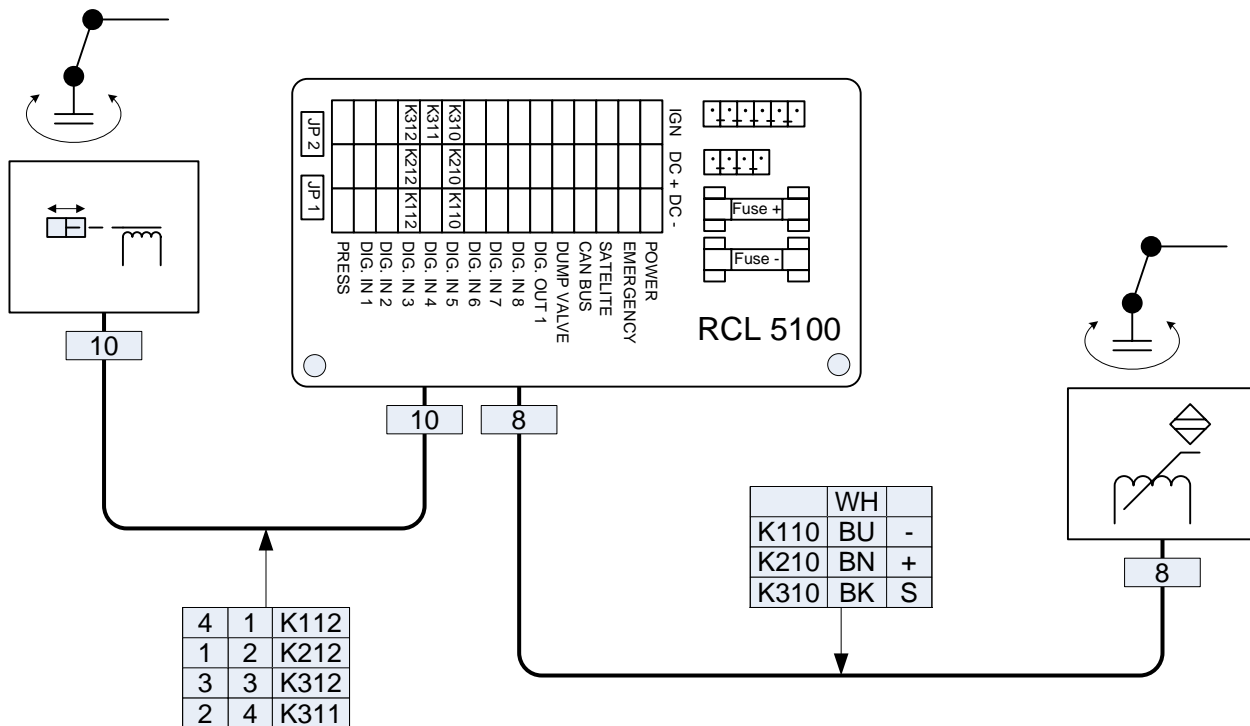

|           |            |       |  |  |            |  |            |
|-----------|------------|-------|--|--|------------|--|------------|
| Ændringer |            |       | Produkt  |  | Dato       |  | Målforhold |
| Nr.       | Dato       | Sign. | RCL 5100   |  | 06.02.1997 |  |            |
| A         | 06.02.1997 | MBJ   | Emne   |  | Erstatter  |  |            |
| B         | 08.12.2005 | BWK   | 2-trins LMB  |  | Tegn nr.   |  |            |
|           |            |       |  <b>Højbjerg Maskinfabrik <math>\frac{a}{s}</math></b><br>Oddervej 200 - DK-8270 Højbjerg |  | 70 20 011  |  |            |
|           |            |       |  |  |            |  | Erstat af  |

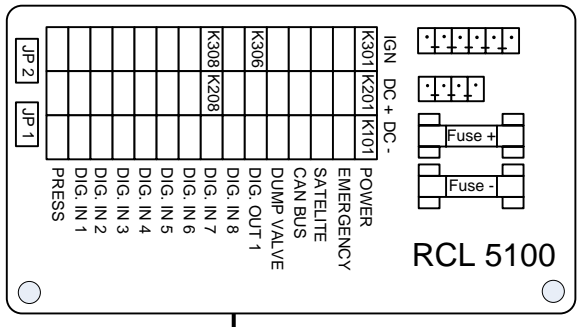
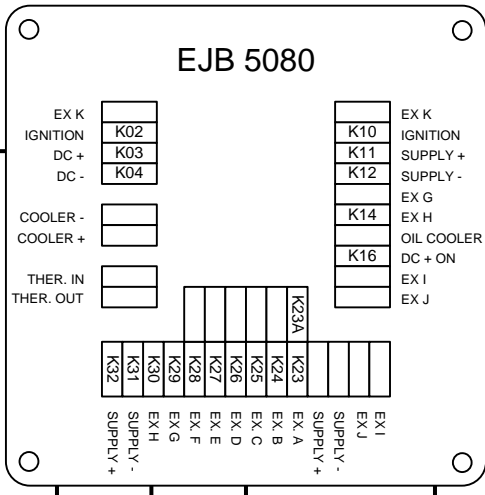

|      |   |      |
|------|---|------|
| K12  | 1 | K101 |
| K11  | 2 | K201 |
| K10  | 3 | K301 |
| K14  | 4 | K306 |
| K16  | 5 | K208 |
|      | 6 |      |
| K23A | 7 | K308 |

|     |   |   |
|-----|---|---|
| K24 | 1 | * |
| K25 | 2 | * |
| K26 | 3 | * |
| K27 | 4 | * |
| K28 | 5 | * |
| K30 | 6 | * |
| K29 | 7 | * |

|     |   |     |
|-----|---|-----|
| K23 | 1 | 1.4 |
|-----|---|-----|

|     |    |              |
|-----|----|--------------|
| K24 | 1  | RPM / AUTO   |
| K25 | 2  | Engine start |
| K26 | 3  | Engine stop  |
| K27 | 4  | RPM +        |
| K28 | 5  | RPM -        |
|     | 6  |              |
|     | 7  |              |
| K02 | 8  | IGN          |
| K03 | RD | +            |
| K04 | BU | -            |

|     |   |     |
|-----|---|-----|
| K32 | 1 | 2.2 |
| K31 | 2 | 1.1 |

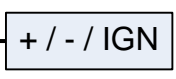
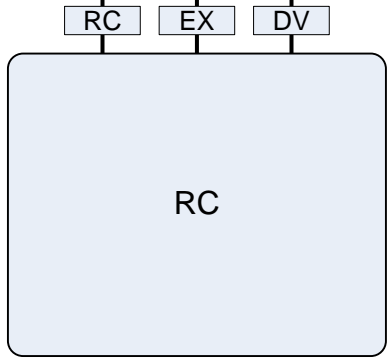

|           |            |      |   |  |            |  |            |  |
|-----------|------------|------|---|--|------------|--|------------|--|
| Ændringer |            |      | Produkt   |  | Dato       |  | Målforhold |  |
| Nr.       | Dato       | Sign | RCL 5100  |  | 18.02.1997 |  |            |  |
| A         | 18.02.1997 | MBJ  |   |  | Sign.      |  | MBJ        |  |
| B         | 12.12.2005 | BWK  | Emne  |  | Erstatter  |  |            |  |
|           |            |      | RC 400  |  | Tegn nr.   |  | 70 20 012  |  |
|           |            |      | <b>Højbjerg Maskinfabrik a/s</b><br>Oddervej 200 - DK-8270 Højbjerg |  | Erstat af  |  |            |  |



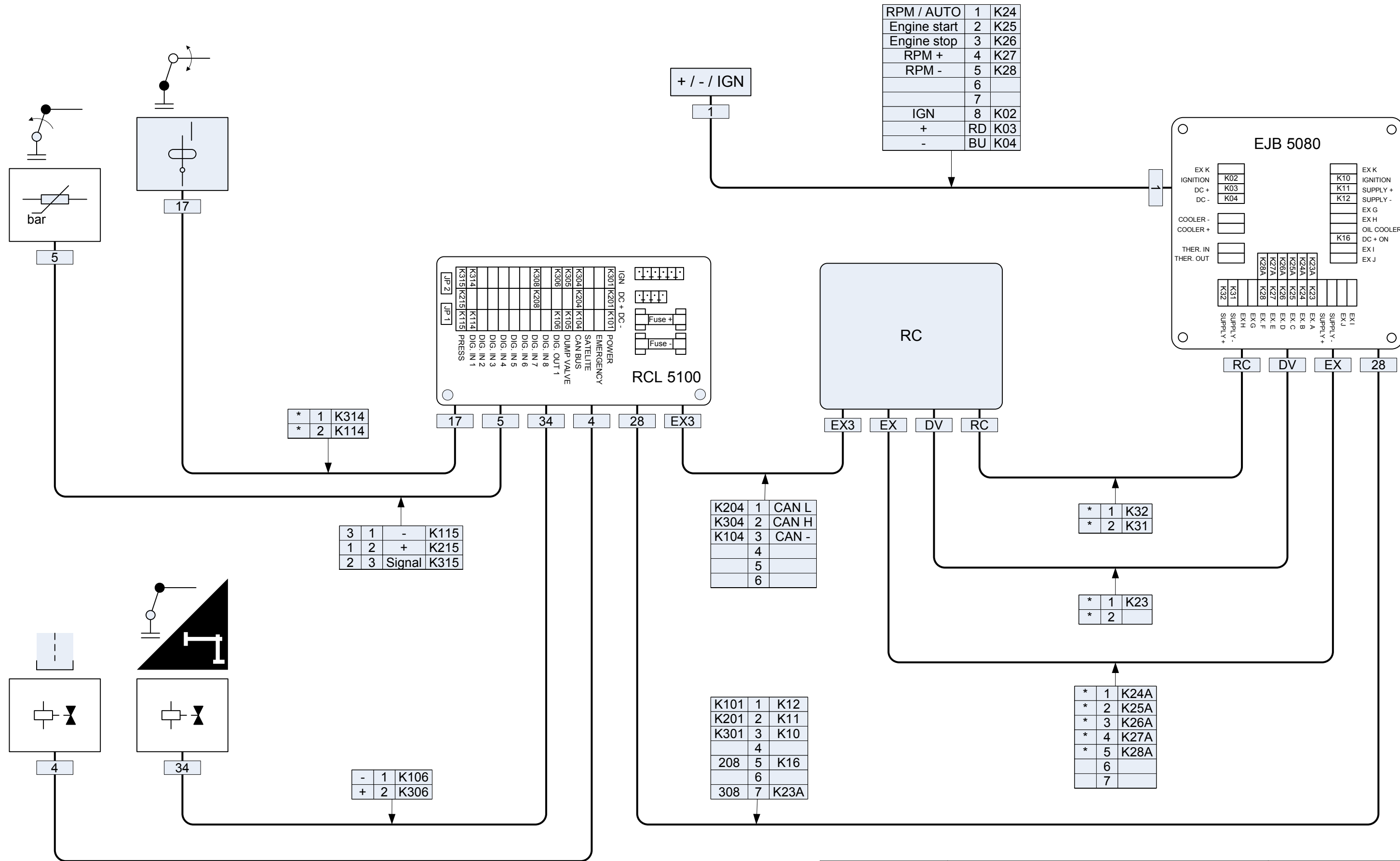

|              |    |     |
|--------------|----|-----|
| RPM / AUTO   | 1  | K24 |
| Engine start | 2  | K25 |
| Engine stop  | 3  | K26 |
| RPM +        | 4  | K27 |
| RPM -        | 5  | K28 |
|              | 6  |     |
|              | 7  |     |
| IGN          | 8  | K02 |
| +            | RD | K03 |
| -            | BU | K04 |

|   |   |      |
|---|---|------|
| * | 1 | K314 |
| * | 2 | K114 |

|   |   |        |      |
|---|---|--------|------|
| 3 | 1 | -      | K115 |
| 1 | 2 | +      | K215 |
| 2 | 3 | Signal | K315 |

|   |   |      |
|---|---|------|
| - | 1 | K106 |
| + | 2 | K306 |

|   |   |        |      |
|---|---|--------|------|
| 1 | 1 | Signal | K305 |
| 2 | 2 | -      | K105 |

|      |   |       |
|------|---|-------|
| K204 | 1 | CAN L |
| K304 | 2 | CAN H |
| K104 | 3 | CAN - |
|      | 4 |       |
|      | 5 |       |
|      | 6 |       |

|      |   |      |
|------|---|------|
| K101 | 1 | K12  |
| K201 | 2 | K11  |
| K301 | 3 | K10  |
|      | 4 |      |
| 208  | 5 | K16  |
|      | 6 |      |
| 308  | 7 | K23A |

|   |   |     |
|---|---|-----|
| * | 1 | K32 |
| * | 2 | K31 |

|   |   |     |
|---|---|-----|
| * | 1 | K23 |
| * | 2 |     |

|   |   |      |
|---|---|------|
| * | 1 | K24A |
| * | 2 | K25A |
| * | 3 | K26A |
| * | 4 | K27A |
| * | 5 | K28A |
|   | 6 |      |
|   | 7 |      |

| Ændringer |            |       |
|-----------|------------|-------|
| Nr.       | Dato       | Sign. |
| A         | 12.03.2001 | PHH   |
| B         | 14.12.2005 | BWK   |
| C         | 06.07.2006 | BWK   |
|           |            |       |
|           |            |       |
|           |            |       |
|           |            |       |

Produkt  
**RCL 5100**

Emne  
**IRC, RC 400**



**Højbjerg Maskinfabrik a/s**  
Oddervej 200 - DK-8270 Højbjerg

|           |            |            |
|-----------|------------|------------|
| Dato      | 12.03.2001 | Målforhold |
| Sign.     | PHH        |            |
| Erstatter |            |            |
| Tegn nr.  |            |            |
| Erstat af |            |            |

70 20 017

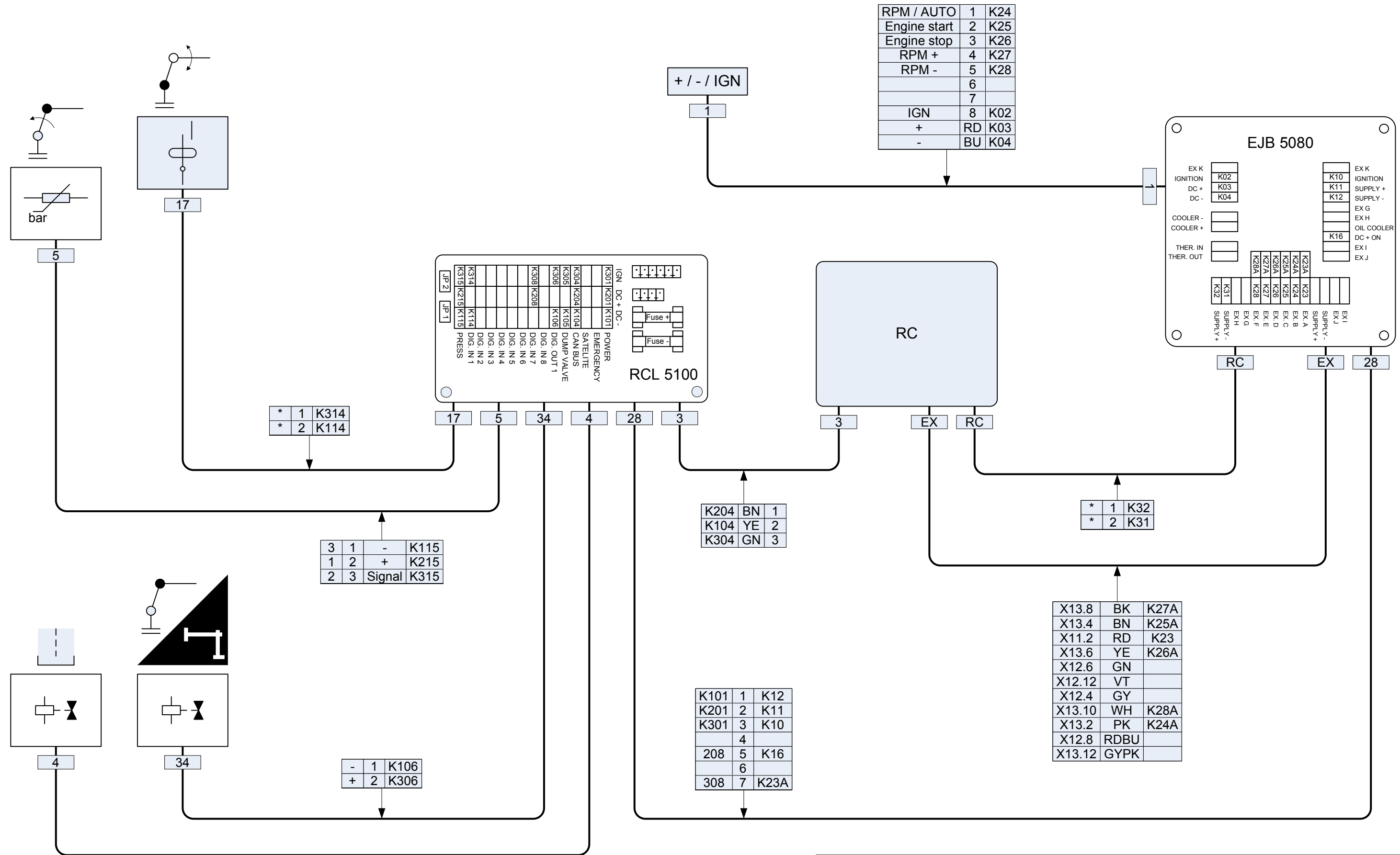

|              |    |     |
|--------------|----|-----|
| RPM / AUTO   | 1  | K24 |
| Engine start | 2  | K25 |
| Engine stop  | 3  | K26 |
| RPM +        | 4  | K27 |
| RPM -        | 5  | K28 |
|              | 6  |     |
|              | 7  |     |
| IGN          | 8  | K02 |
| +            | RD | K03 |
| -            | BU | K04 |

|   |   |      |
|---|---|------|
| * | 1 | K314 |
| * | 2 | K114 |

|   |   |        |      |
|---|---|--------|------|
| 3 | 1 | -      | K115 |
| 1 | 2 | +      | K215 |
| 2 | 3 | Signal | K315 |

|   |   |      |
|---|---|------|
| - | 1 | K106 |
| + | 2 | K306 |

|   |   |        |      |
|---|---|--------|------|
| 1 | 1 | Signal | K305 |
| 2 | 2 | -      | K105 |

|      |    |   |
|------|----|---|
| K204 | BN | 1 |
| K104 | YE | 2 |
| K304 | GN | 3 |

|      |   |      |
|------|---|------|
| K101 | 1 | K12  |
| K201 | 2 | K11  |
| K301 | 3 | K10  |
|      | 4 |      |
| 208  | 5 | K16  |
|      | 6 |      |
| 308  | 7 | K23A |

|   |   |     |
|---|---|-----|
| * | 1 | K32 |
| * | 2 | K31 |

|        |      |      |
|--------|------|------|
| X13.8  | BK   | K27A |
| X13.4  | BN   | K25A |
| X11.2  | RD   | K23  |
| X13.6  | YE   | K26A |
| X12.6  | GN   |      |
| X12.12 | VT   |      |
| X12.4  | GY   |      |
| X13.10 | WH   | K28A |
| X13.2  | PK   | K24A |
| X12.8  | RDBU |      |
| X13.12 | GYPK |      |

| Ændringer |            |       |
|-----------|------------|-------|
| Nr.       | Dato       | Sign. |
| A         | 12.03.2001 | PHH   |
| B         | 15.12.2005 | BWK   |
| C         | 06.07.2006 | BWK   |

Produkt  
**RCL 5100**

Emne  
**IRC, BMS-1**



**Højbjerg Maskinfabrik a/s**  
Oddervej 200 - DK-8270 Højbjerg

|           |            |            |
|-----------|------------|------------|
| Dato      | 12.03.2001 | Målforhold |
| Sign.     | PHH        |            |
| Erstatter |            |            |
| Tegn nr.  |            |            |
| Erstat af |            |            |

70 20 018

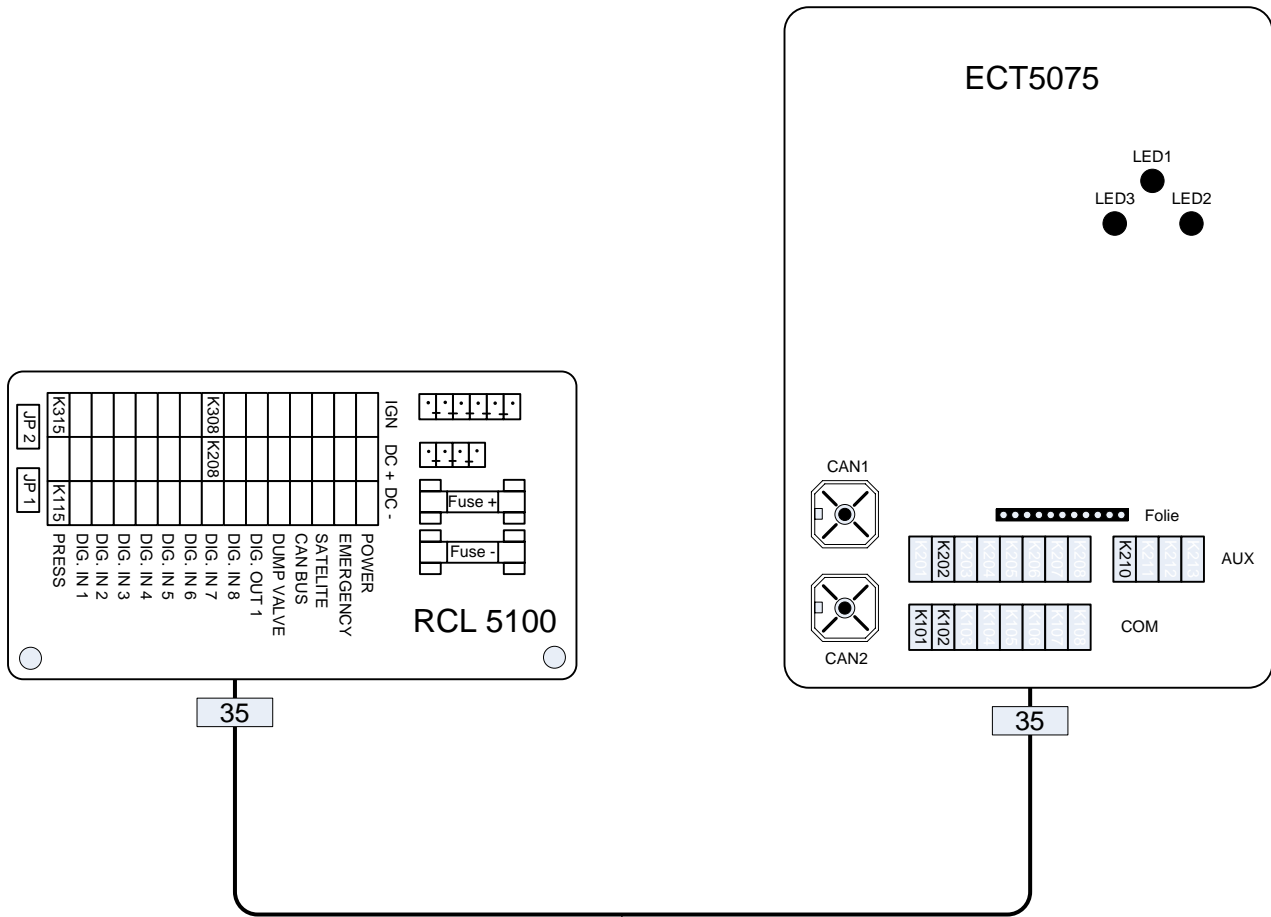

|      |   |      |
|------|---|------|
| K115 | 1 | K101 |
| K208 | 2 | K102 |
| K315 | 3 | K202 |
| K308 | 4 | K210 |
|      | 5 |      |

|           |            |       |   |  |            |  |            |
|-----------|------------|-------|---|--|------------|--|------------|
| Ændringer |            |       | Produkt   |  | Dato       |  | Målforhold |
| Nr.       | Dato       | Sign. | RCL 5100  |  | 09.03.2004 |  |            |
| A         | 09.03.2004 | PHH   | Emne  |  | Sign.      |  | Erstatter  |
| B         | 16.12.2005 | BWK   |   |  | ECT 5075   |  |            |
|           |            |       |  <b>Højbjerg Maskinfabrik <sup>a</sup>/<sub>s</sub></b><br>Oddervej 200 - DK-8270 Højbjerg |  | Tegn nr.   |  | 70 20 019  |
|           |            |       |   |  | Erstat af  |  |            |
|           |            |       |   |  |            |  |            |

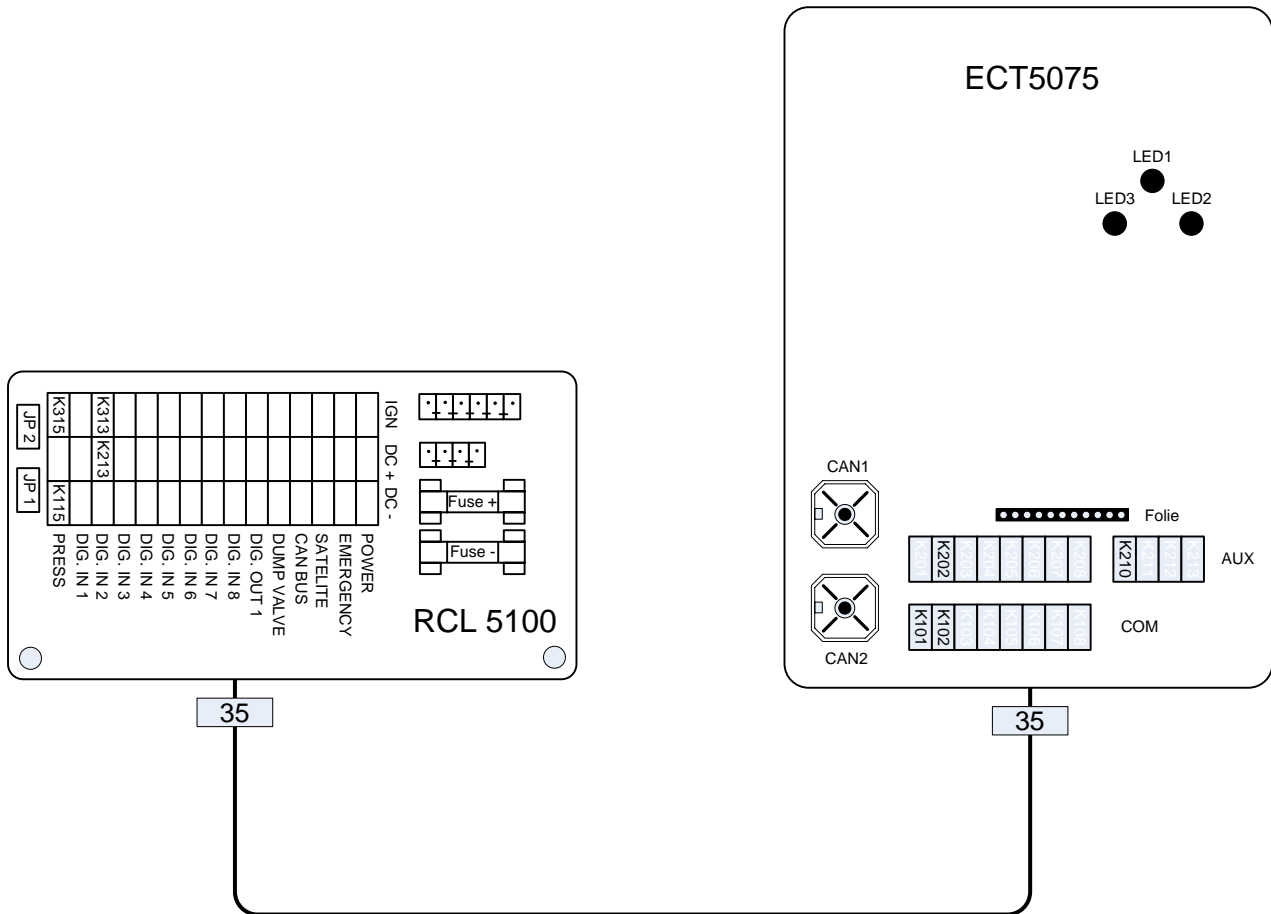

|      |   |      |
|------|---|------|
| K115 | 1 | K101 |
| K213 | 2 | K102 |
| K315 | 3 | K202 |
| K313 | 4 | K210 |
|      | 5 |      |

|           |            |       |  |  |                  |  |            |
|-----------|------------|-------|--|--|------------------|--|------------|
| Ændringer |            |       | Produkt  |  | Dato             |  | Målforhold |
| Nr.       | Dato       | Sign. | RCL 5100   |  | 09.03.2004       |  |            |
| A         | 09.03.2004 | PHH   | Emne   |  | Sign.            |  | Erstatter  |
| B         | 16.12.2005 | BWK   |  |  | ECT 5075 med IRC |  |            |
|           |            |       |  <b>Højbjerg Maskinfabrik</b> <sup>a/s</sup><br>Oddervej 200 - DK-8270 Højbjerg |  | Tegn nr.         |  | 70 20 021  |
|           |            |       |  |  | Erstat af        |  |            |

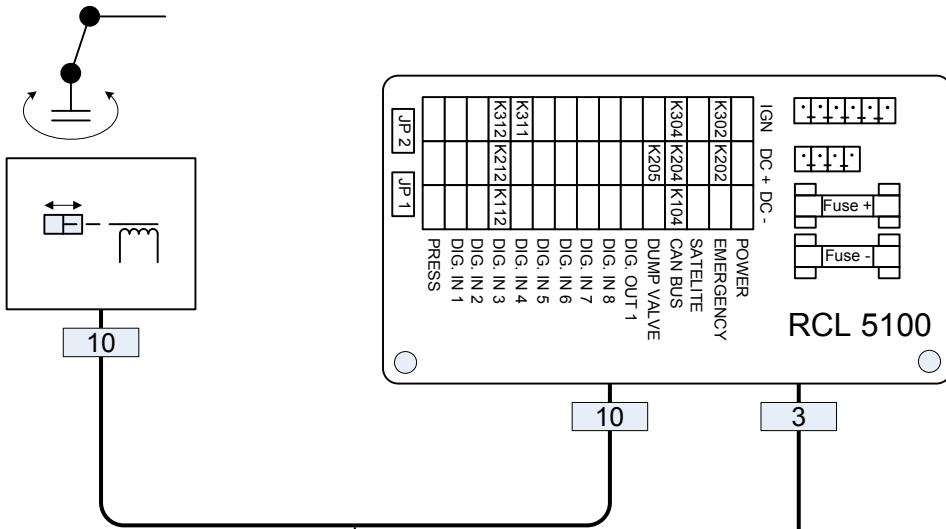

|   |   |      |
|---|---|------|
| 4 | 1 | K112 |
| 1 | 2 | K212 |
| 3 | 3 | K312 |
| 2 | 4 | K311 |

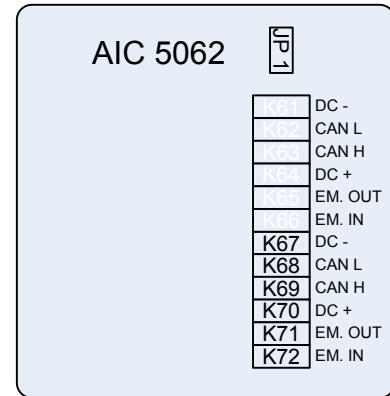

|      |    |     |
|------|----|-----|
| K302 | 1  | K72 |
| K202 | 2  | K71 |
| K204 | BN | K68 |
| K205 | YE | K70 |
| K104 | GN | K67 |
| K304 | WH | K69 |

|           |            |       |  |  |            |  |            |  |
|-----------|------------|-------|--|--|------------|--|------------|--|
| Ændringer |            |       | Produkt  |  | Dato       |  | Målforhold |  |
| Nr.       | Dato       | Sign. | RCL 5100   |  | 21.12.1998 |  |            |  |
| A         | 21.12.1998 | MBJ   |  |  | Sign.      |  | MBJ        |  |
| B         | 18.01.2006 | BWK   | Emne   |  | Erstatter  |  |            |  |
| C         | 23.08.2006 | BWK   | EVS, SLM   |  | Tegn nr.   |  | 70 20 022  |  |
|           |            |       |  <b>Højbjerg Maskinfabrik</b> <sup>a/s</sup><br>Oddervej 200 - DK-8270 Højbjerg |  | Erstat af  |  |            |  |
|           |            |       |  |  |            |  |            |  |

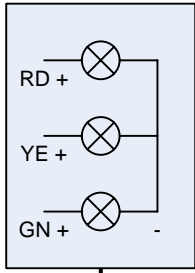

33

|      |   |       |
|------|---|-------|
| -    | 1 | OUT - |
| GN + | 2 | OUT 1 |
| YE + | 3 | OUT 2 |
| RD + | 4 | OUT 3 |

33

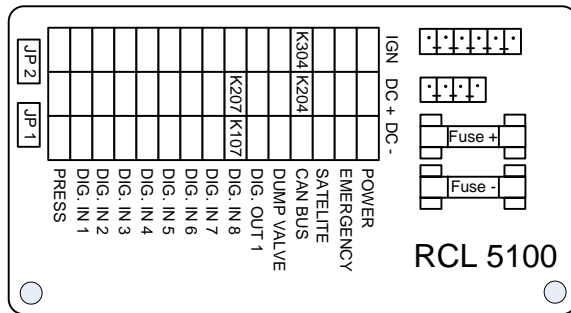
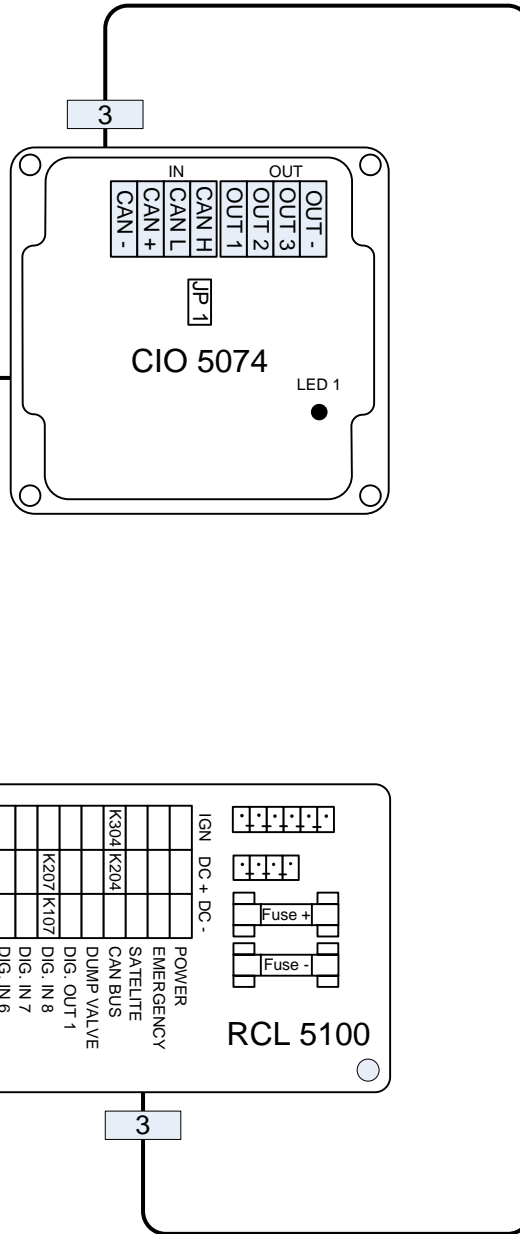

3

|      |    |       |
|------|----|-------|
| K107 | 1  | CAN - |
| K207 | 2  | CAN + |
| K204 | BN | CAN L |
|      | YE |       |
|      | GN |       |
| K304 | WH | CAN H |

| Ændringer |            |      |
|-----------|------------|------|
| Nr.       | Dato       | Sign |
| A         | 24.02.2004 | PHH  |
| B         | 24.02.2004 | PHH  |
| C         | 20.12.2005 | BWK  |
|           |            |      |
|           |            |      |
|           |            |      |

|   |                 |
|---|-----------------|
| Produkt   | <b>RCL 5100</b> |
| Emne  | <b>CIO 5074</b> |
|  <b>Højbjerg Maskinfabrik <sup>a</sup>/<sub>s</sub></b><br>Oddervej 200 - DK-8270 Højbjerg |                 |

|           |                   |            |
|-----------|-------------------|------------|
| Dato      | <b>24.02.2004</b> | Målforhold |
| Sign.     | <b>PHH</b>        |            |
| Erstatter |                   |            |
| Tegn nr.  | <b>70 20 024</b>  |            |
| Erstat af |                   |            |

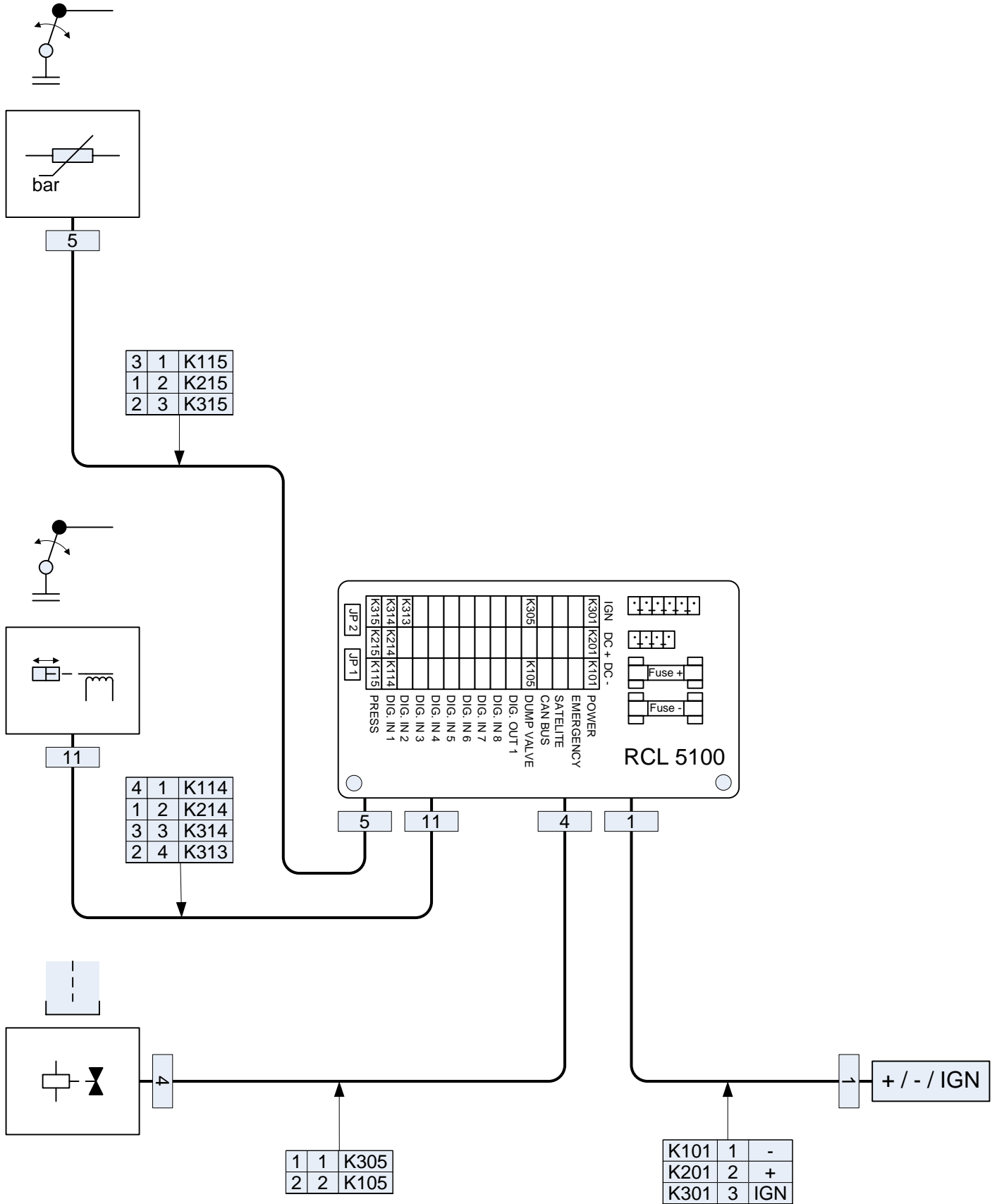

| Ændringer |           |      |
|-----------|-----------|------|
| Nr.       | Dato      | Sign |
| A         | 30.11.205 | BWK  |
|           |           |      |
|           |           |      |
|           |           |      |
|           |           |      |

Produkt  
**RCL 5100**

Emne  
**Standard og TS**

**Højbjerg Maskinfabrik <sup>2</sup>/<sub>5</sub>**  
Oddervej 200 - DK-8270 Højbjerg

|           |                         |            |
|-----------|-------------------------|------------|
| Dato      | <b>30.11.205</b>        | Målforhold |
| Sign.     | <b>BWK</b>              |            |
| Erstatter | <b>7020001, 7020003</b> |            |
| Tegn nr.  | <b>70 20 031</b>        |            |
| Erstat af |                         |            |

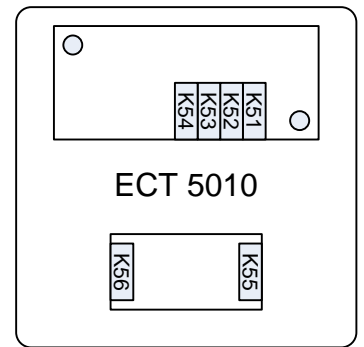
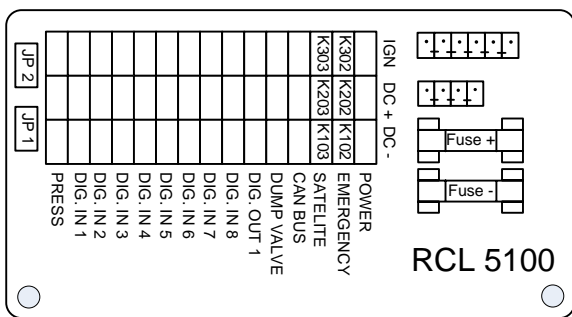

|      |    |     |
|------|----|-----|
| K302 | 1  | K55 |
| K202 | 2  | K56 |
| K102 | GN | K54 |
| K303 | WH | K53 |
| K302 | BN | K52 |
| K301 | YE | K51 |

|           |            |       |  |  |            |  |            |     |
|-----------|------------|-------|--|--|------------|--|------------|-----|
| Ændringer |            |       | Produkt  |  | Dato       |  | Målforhold |     |
| Nr.       | Dato       | Sign. | RCL 5100   |  | 25.08.2005 |  |            |     |
| A         | 25.08.2005 | BWK   | Emne   |  | Sign.      |  | Erstatter  |     |
| B         | 07.12.2005 | BWK   |  |  | ECT 5010   |  |            | BWK |
|           |            |       |  <b>Højbjerg Maskinfabrik <sup>a/s</sup></b><br>Oddervej 200 - DK-8270 Højbjerg |  | Tegn nr.   |  | 70 20 032  |     |
|           |            |       |  |  | Erstat af  |  |            |     |
|           |            |       |  |  |            |  |            |     |



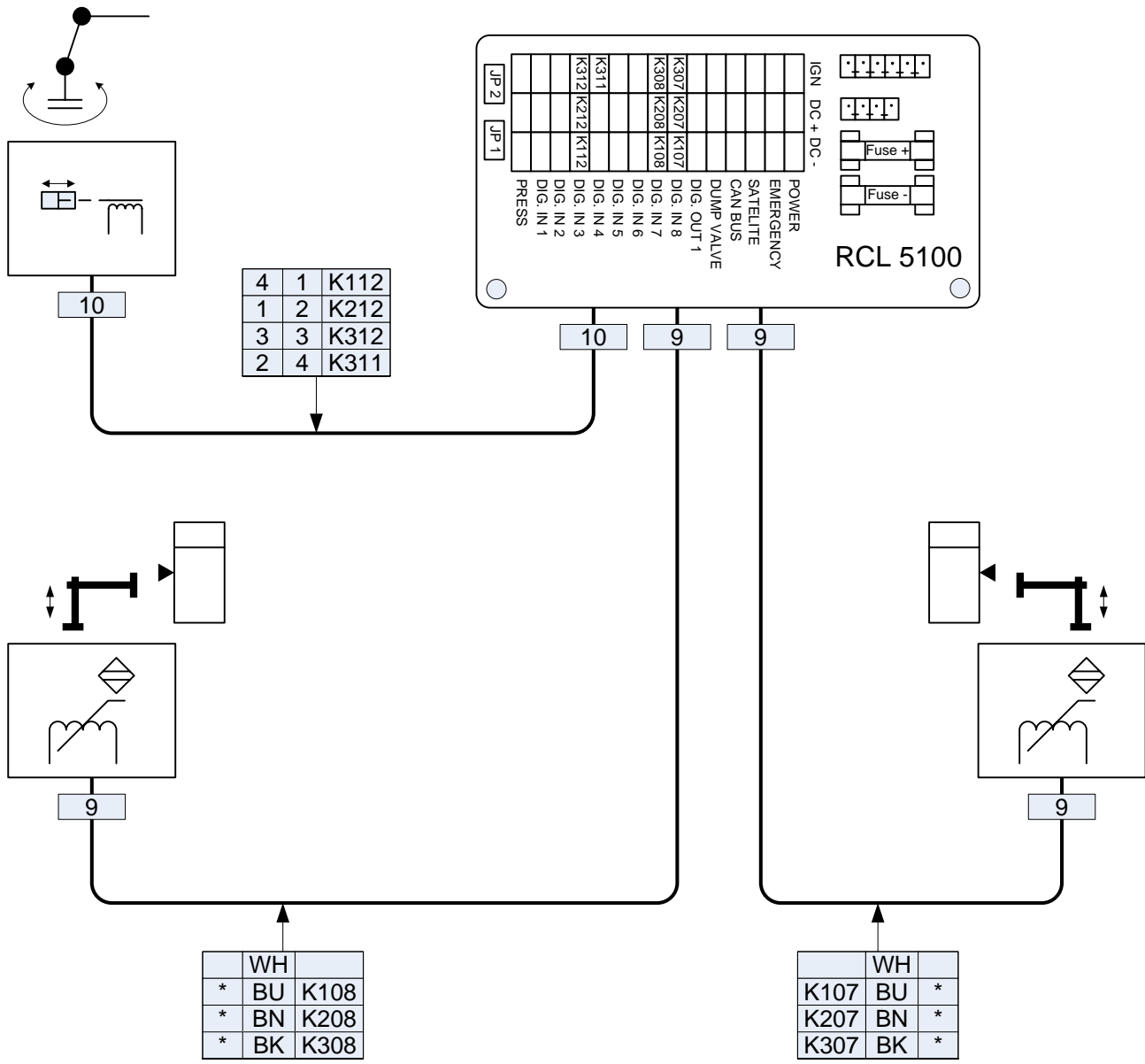

|           |            |      |   |  |                               |  |            |
|-----------|------------|------|---|--|-------------------------------|--|------------|
| Ændringer |            |      | Produkt   |  | Dato                          |  | Målforhold |
| Nr.       | Dato       | Sign | RCL 5100  |  | 24.09.1998                    |  |            |
| A         | 24.09.1998 | MBJ  | Emne  |  | Sign.                         |  | Erstatter  |
| B         | 14.12.2005 | BWK  |   |  | Støtteben ned, aftaster sving |  |            |
|           |            |      |  <b>Højbjerg Maskinfabrik <sup>2</sup>/<sub>5</sub></b><br>Oddervej 200 - DK-8270 Højbjerg |  | Tegn nr.                      |  | 70 20 033  |
|           |            |      |   |  | Erstat af                     |  |            |

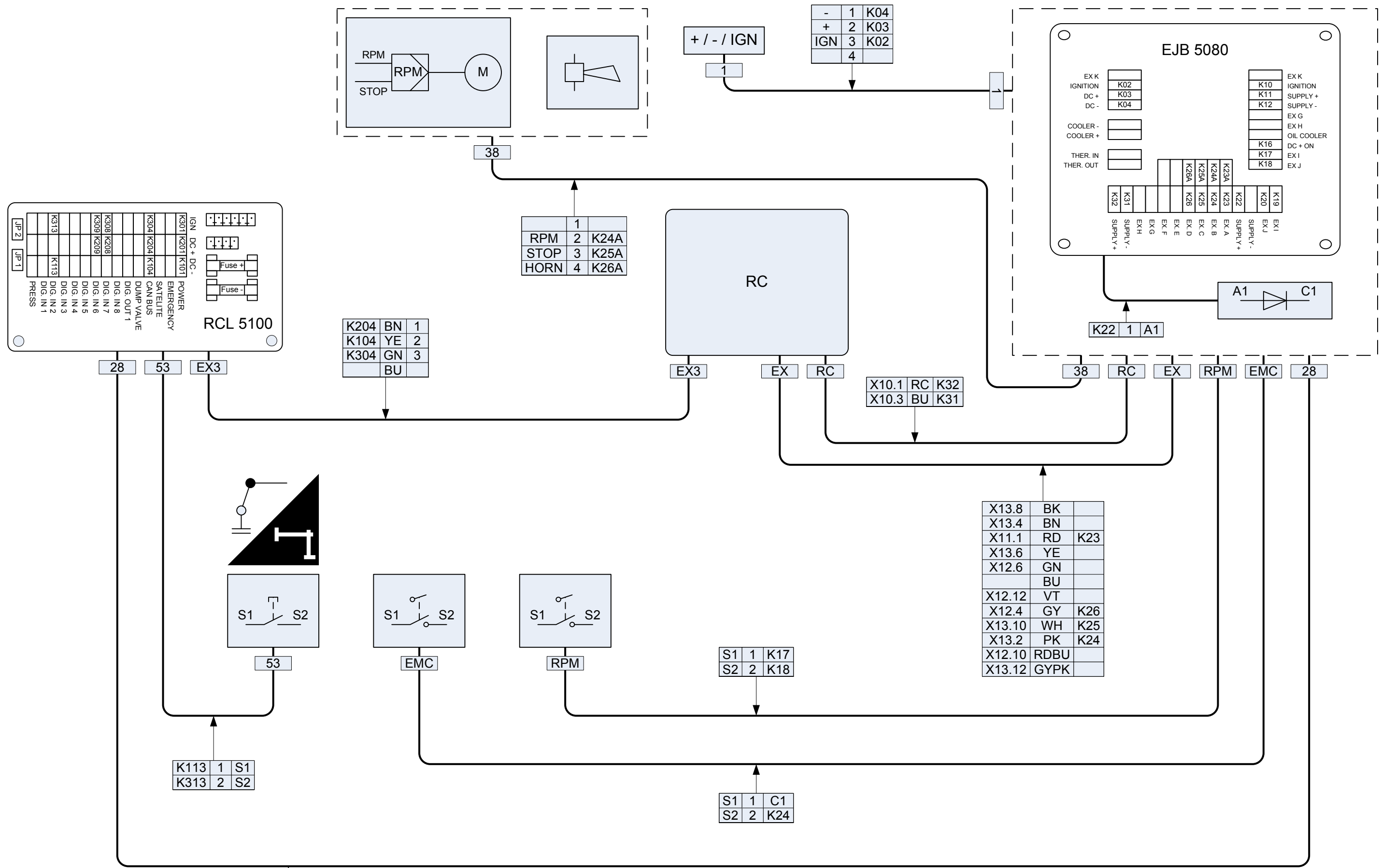

|      |   |      |
|------|---|------|
| K101 | 1 | K12  |
| K201 | 2 | K11  |
| K301 | 3 | K10  |
| K208 | 4 | K16  |
| K308 | 5 | K23A |
| K209 | 6 | K19  |
| K309 | 7 | K20  |

|      |   |      |
|------|---|------|
| 1    |   |      |
| RPM  | 2 | K24A |
| STOP | 3 | K25A |
| HORN | 4 | K26A |

|      |    |   |
|------|----|---|
| K204 | BN | 1 |
| K104 | YE | 2 |
| K304 | GN | 3 |
|      | BU |   |

|     |   |     |
|-----|---|-----|
| -   | 1 | K04 |
| +   | 2 | K03 |
| IGN | 3 | K02 |
|     | 4 |     |

|       |    |     |
|-------|----|-----|
| X10.1 | RC | K32 |
| X10.3 | BU | K31 |

|        |      |     |
|--------|------|-----|
| X13.8  | BK   |     |
| X13.4  | BN   |     |
| X11.1  | RD   | K23 |
| X13.6  | YE   |     |
| X12.6  | GN   |     |
|        | BU   |     |
| X12.12 | VT   |     |
| X12.4  | GY   | K26 |
| X13.10 | WH   | K25 |
| X13.2  | PK   | K24 |
| X12.10 | RDBU |     |
| X13.12 | GYPK |     |

|    |   |     |
|----|---|-----|
| S1 | 1 | K17 |
| S2 | 2 | K18 |

|    |   |     |
|----|---|-----|
| S1 | 1 | C1  |
| S2 | 2 | K24 |

| Ændringer |            |       |
|-----------|------------|-------|
| Nr.       | Dato       | Sign. |
| A         | 11.01.2006 | BWK   |
|           |            |       |
|           |            |       |
|           |            |       |
|           |            |       |
|           |            |       |
|           |            |       |
|           |            |       |
|           |            |       |
|           |            |       |

Produkt  
**RCL 5100**

Emne  
**IMT 24562 (1)**



**Højbjerg Maskinfabrik a/s**  
Oddervej 200 - DK-8270 Højbjerg

|           |            |            |
|-----------|------------|------------|
| Dato      | 11.01.2006 | Målforhold |
| Sign.     | BWK        |            |
| Erstatter | 7020027    |            |
| Tegn nr.  |            |            |
| Erstat af |            |            |

70 20 034

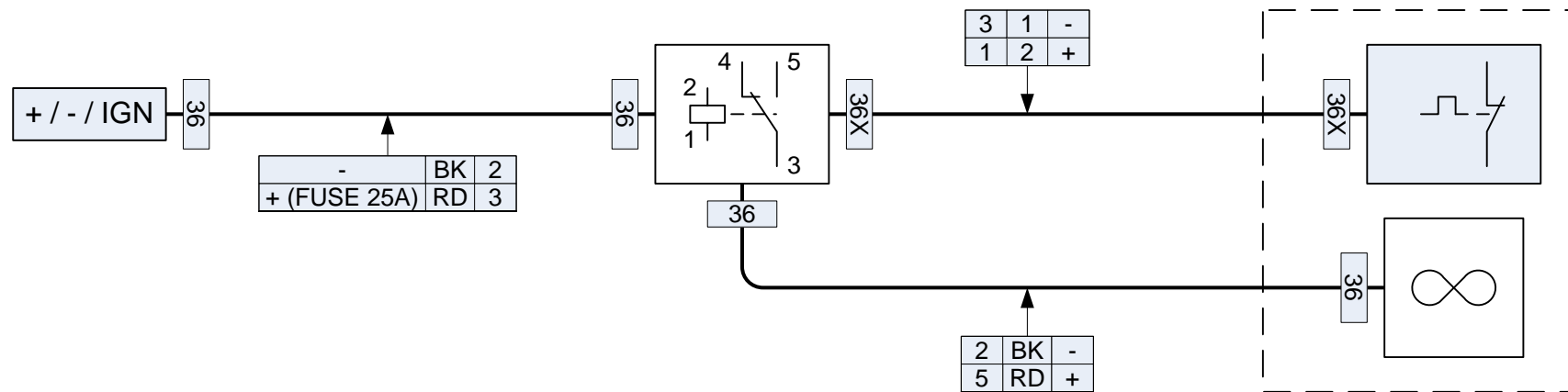
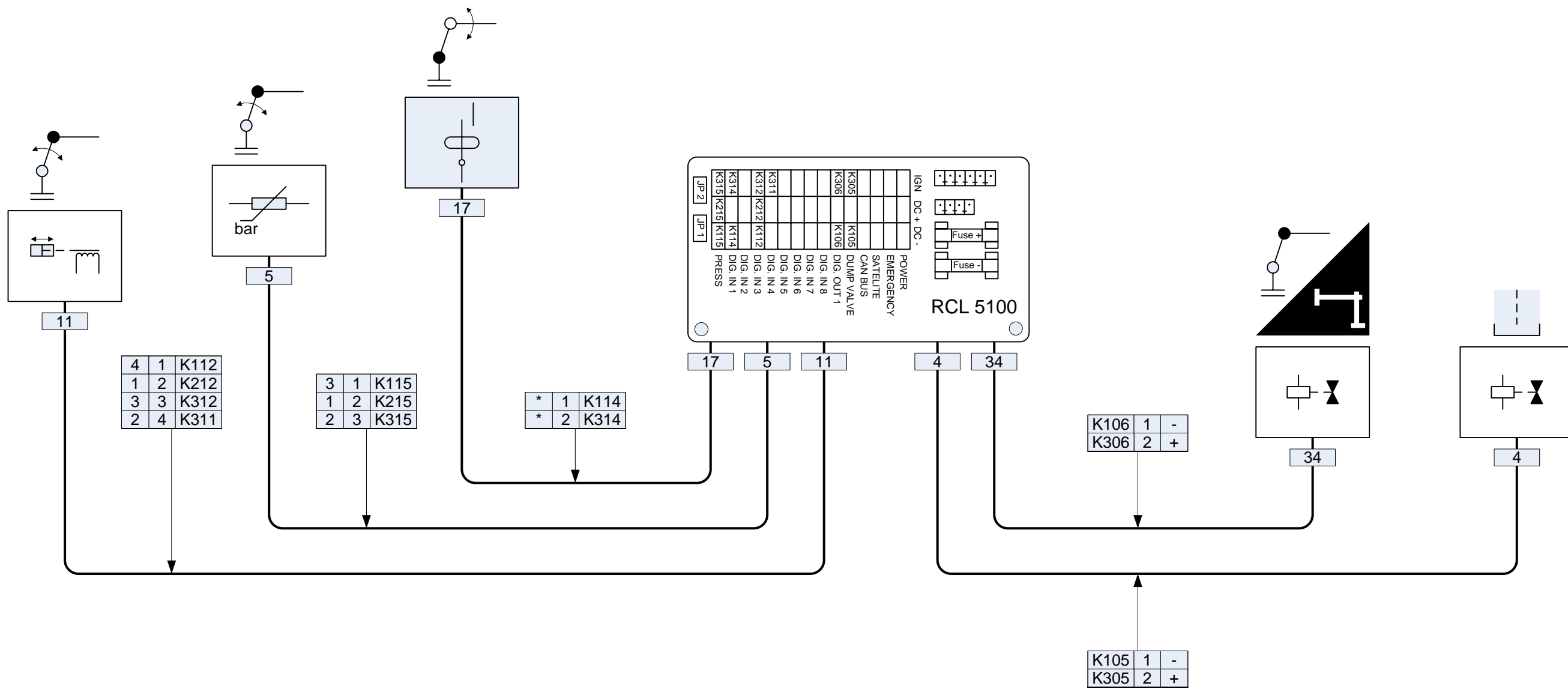

| Ændringer |            |       |
|-----------|------------|-------|
| Nr.       | Dato       | Sign. |
| A         | 11.01.2006 | BWK   |
|           |            |       |
|           |            |       |
|           |            |       |
|           |            |       |
|           |            |       |

|   |               |
|---|---------------|
| Produkt   | RCL 5100      |
| Emne  | IMT 24562 (2) |
|  <b>Højbjerg Maskinfabrik a/s</b><br>Oddervej 200 - DK-8270 Højbjerg |               |

|           |            |            |
|-----------|------------|------------|
| Dato      | 11.01.2006 | Målforhold |
| Sign.     | BWK        |            |
| Erstatter | 7020027    |            |
| Tegn nr.  |            | 70 20 035  |
| Erstat af |            |            |

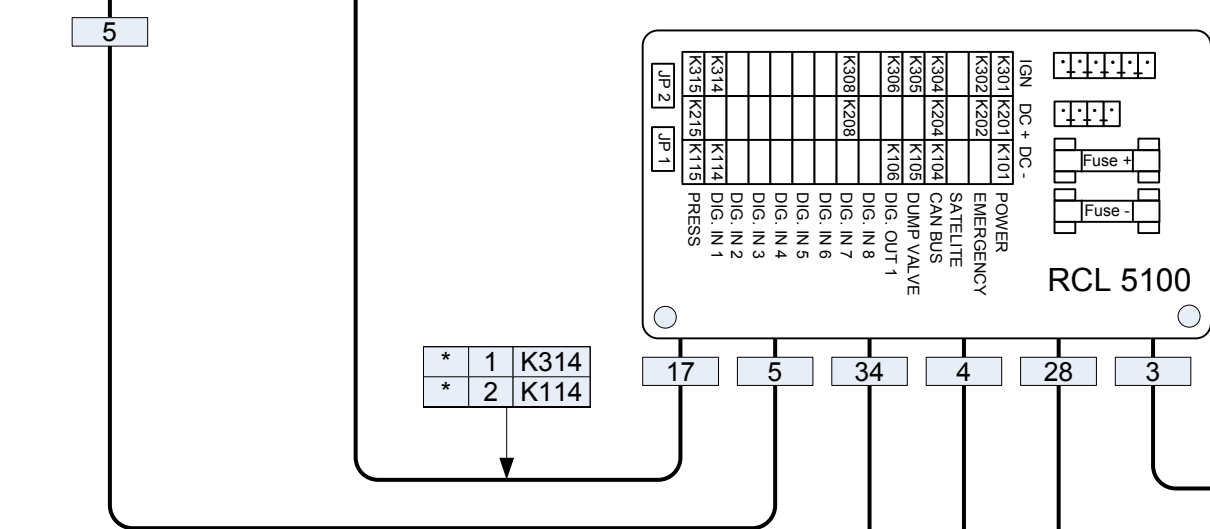
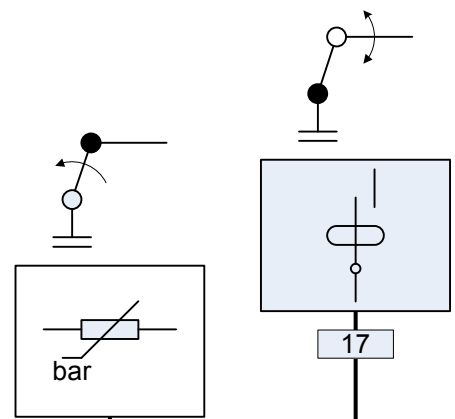

|   |   |      |
|---|---|------|
| * | 1 | K314 |
| * | 2 | K114 |

|   |   |        |      |
|---|---|--------|------|
| 3 | 1 | -      | K115 |
| 1 | 2 | +      | K215 |
| 2 | 3 | Signal | K315 |

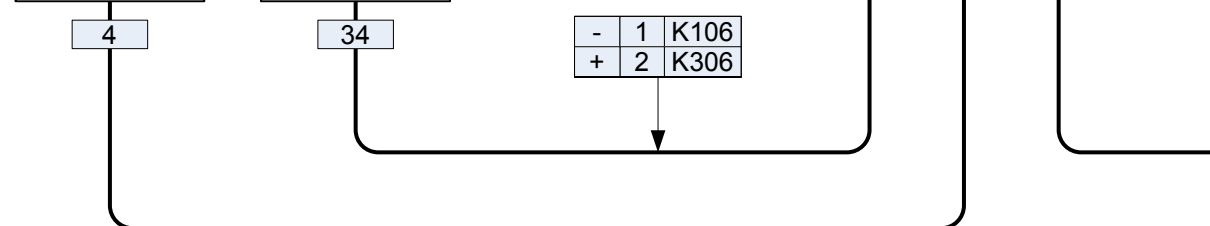
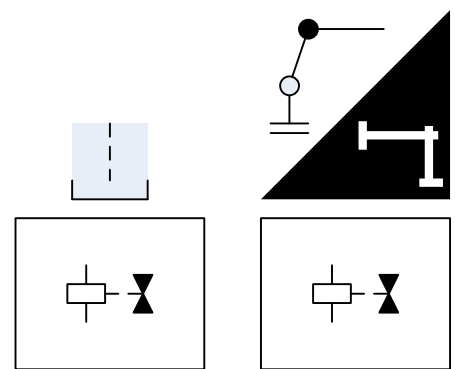

|   |   |      |
|---|---|------|
| - | 1 | K106 |
| + | 2 | K306 |

|   |   |        |      |
|---|---|--------|------|
| 1 | 1 | Signal | K305 |
| 2 | 2 | -      | K105 |

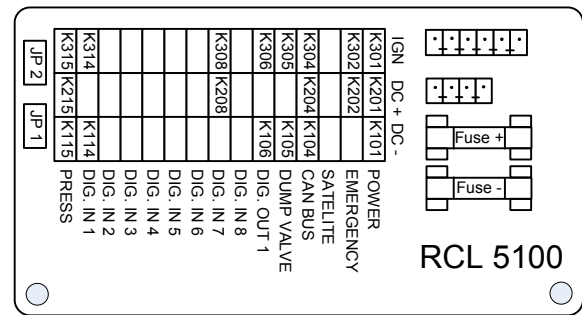

|      |    |       |     |
|------|----|-------|-----|
| K302 | 1  | Stop  | K72 |
| K202 | 2  | Stop  | K71 |
| K204 | BN | CAN L | K68 |
|      | YE | +     | K70 |
| K104 | GN | -     | K67 |
| K304 | WH | CAN H | K69 |

|     |   |       |
|-----|---|-------|
| K62 | 1 | CAN L |
| K63 | 2 | CAN H |
| K61 | 3 | CAN - |
|     | 4 |       |
|     | 5 |       |
|     | 6 |       |

|      |   |      |
|------|---|------|
| K101 | 1 | K12  |
| K201 | 2 | K11  |
| K301 | 3 | K10  |
|      | 4 |      |
| K208 | 5 | K16  |
|      | 6 |      |
| K308 | 7 | K23A |

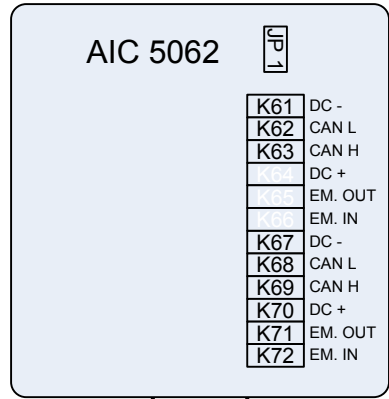

|              |    |     |
|--------------|----|-----|
| RPM / AUTO   | 1  | K24 |
| Engine start | 2  | K25 |
| Engine stop  | 3  | K26 |
| RPM +        | 4  | K27 |
| RPM -        | 5  | K28 |
|              | 6  |     |
|              | 7  |     |
| IGN          | 8  | K02 |
| +            | RD | K03 |
| -            | BU | K04 |

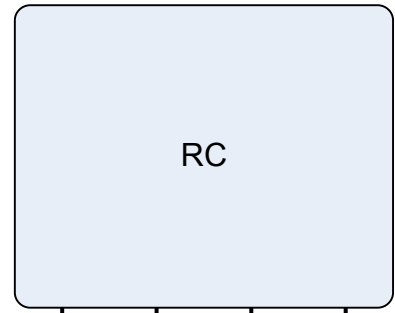
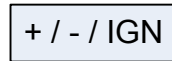

|   |   |     |
|---|---|-----|
| * | 1 | K32 |
| * | 2 | K31 |

|   |   |     |
|---|---|-----|
| * | 1 | K23 |
| * | 2 |     |

|   |   |      |
|---|---|------|
| * | 1 | K24A |
| * | 2 | K25A |
| * | 3 | K26A |
| * | 4 | K27A |
| * | 5 | K28A |
|   | 6 |      |
|   | 7 |      |

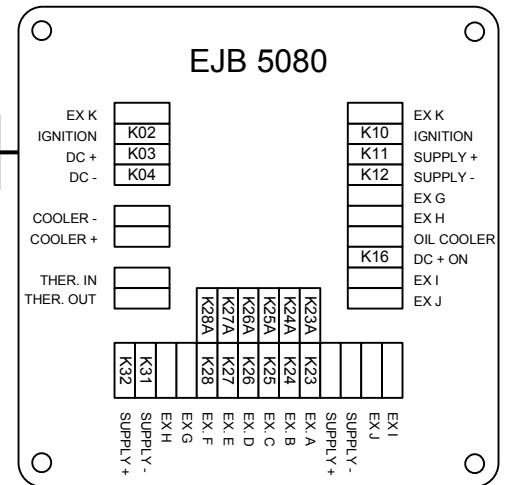

| Ændringer |            |       |
|-----------|------------|-------|
| Nr.       | Dato       | Sign. |
| A         | 24.02.2006 | PHH   |
| B         | 06.07.2006 | BWK   |
| C         | 23.08.2006 | BWK   |

Produkt  
**RCL 5100**

Emne  
**EVS, IRC, RC 400**



**Højbjerg Maskinfabrik a/s**  
Oddervej 200 - DK-8270 Højbjerg

|           |            |            |
|-----------|------------|------------|
| Dato      | 24.02.2006 | Målforhold |
| Sign.     | PHH        |            |
| Erstatter |            |            |
| Tegn nr.  |            |            |
| Erstat af |            |            |

70 20 036

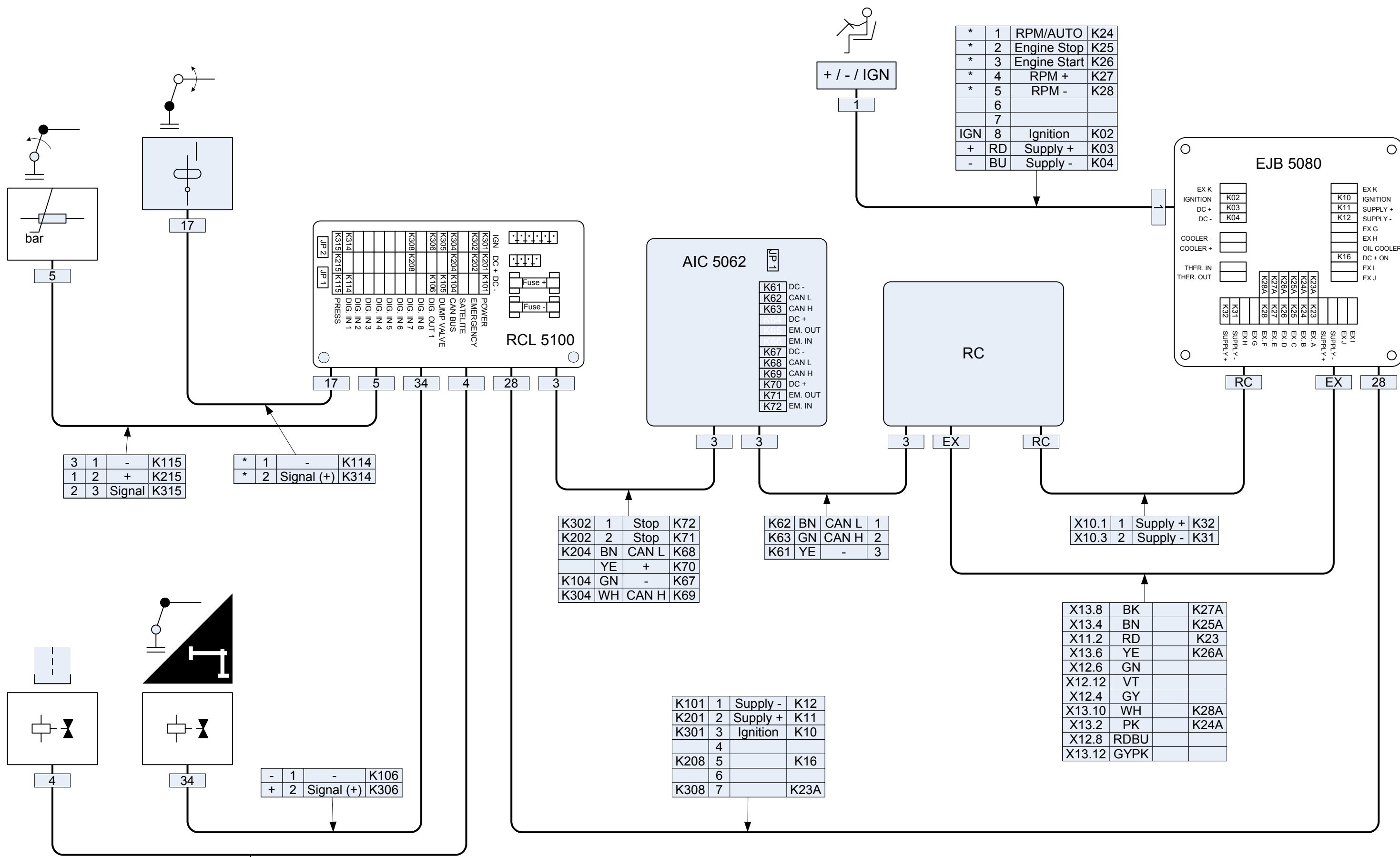

|     |    |              |     |
|-----|----|--------------|-----|
| *   | 1  | RPM/AUTO     | K24 |
| *   | 2  | Engine Stop  | K25 |
| *   | 3  | Engine Start | K26 |
| *   | 4  | RPM +        | K27 |
| *   | 5  | RPM -        | K28 |
|     | 6  |              |     |
|     | 7  |              |     |
| IGN | 8  | Ignition     | K02 |
| +   | RD | Supply +     | K03 |
| -   | BU | Supply -     | K04 |

|   |   |        |      |
|---|---|--------|------|
| 3 | 1 | -      | K115 |
| 1 | 2 | +      | K215 |
| 2 | 3 | Signal | K315 |

|   |   |            |      |
|---|---|------------|------|
| * | 1 | -          | K114 |
| * | 2 | Signal (+) | K314 |

|      |    |       |     |
|------|----|-------|-----|
| K302 | 1  | Stop  | K72 |
| K202 | 2  | Stop  | K71 |
| K204 | BN | CAN L | K68 |
|      | YE | +     | K70 |
| K104 | GN | -     | K67 |
| K304 | WH | CAN H | K69 |

|     |    |       |   |
|-----|----|-------|---|
| K62 | BN | CAN L | 1 |
| K63 | GN | CAN H | 2 |
| K61 | YE | -     | 3 |

|       |   |          |     |
|-------|---|----------|-----|
| X10.1 | 1 | Supply + | K32 |
| X10.3 | 2 | Supply - | K31 |

|        |      |  |      |
|--------|------|--|------|
| X13.8  | BK   |  | K27A |
| X13.4  | BN   |  | K25A |
| X11.2  | RD   |  | K23  |
| X13.6  | YE   |  | K26A |
| X12.6  | GN   |  |      |
| X12.12 | VT   |  |      |
| X12.4  | GY   |  |      |
| X13.10 | WH   |  | K28A |
| X13.2  | PK   |  | K24A |
| X12.8  | RDBU |  |      |
| X13.12 | GYPK |  |      |

|   |   |            |      |
|---|---|------------|------|
| - | 1 | -          | K106 |
| + | 2 | Signal (+) | K306 |

|      |   |          |      |
|------|---|----------|------|
| K101 | 1 | Supply - | K12  |
| K201 | 2 | Supply + | K11  |
| K301 | 3 | Ignition | K10  |
|      | 4 |          |      |
| K208 | 5 |          | K16  |
|      | 6 |          |      |
| K308 | 7 |          | K23A |

|    |   |        |      |
|----|---|--------|------|
| 11 | 1 | Signal | K305 |
| 2  | 2 | -      | K301 |

| Ændringer |            |       |
|-----------|------------|-------|
| Nr.       | Dato       | Sign. |
| A         | 27.06.2006 | BWK   |
| B         | 06.07.2006 | BWK   |
| C         | 23.08.2006 | BWK   |

Produkt  
**RCL 5100**

Emne  
**EVS, IRC, BMS-1**



**Højbjerg Maskinfabrik a/s**  
Oddervej 200 - DK-8270 Højbjerg

|           |            |            |
|-----------|------------|------------|
| Dato      | 27.06.2006 | Målforhold |
| Sign.     | BWK        |            |
| Erstatter |            |            |
| Tegn nr.  |            |            |
| Erstat af |            |            |

70 20 037

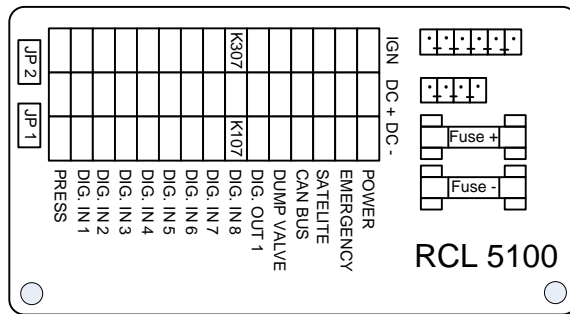

53

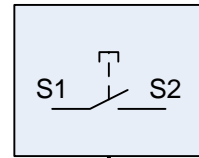
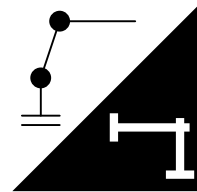

53

|      |   |   |  |
|------|---|---|--|
| K107 | 1 | + |  |
| K307 | 2 | S |  |

|           |            |       |  |  |            |  |            |
|-----------|------------|-------|--|--|------------|--|------------|
| Ændringer |            |       | Produkt  |  | Dato       |  | Målforhold |
| Nr.       | Dato       | Sign. | RCL 5100   |  | 29.03.2006 |  |            |
| A         | 29.03.2006 | PHH   |  |  | Sign.      |  | PHH        |
| B         |            |       | Emne   |  | Erstatter  |  |            |
|           |            |       | Stabilizer button activation   |  | Tegn nr.   |  | 70 20 038  |
|           |            |       |  <b>Højbjerg Maskinfabrik</b> <sup>Å</sup><br>Oddervej 200 - DK-8270 Højbjerg |  | Erstat af  |  |            |
|           |            |       |  |  |            |  |            |

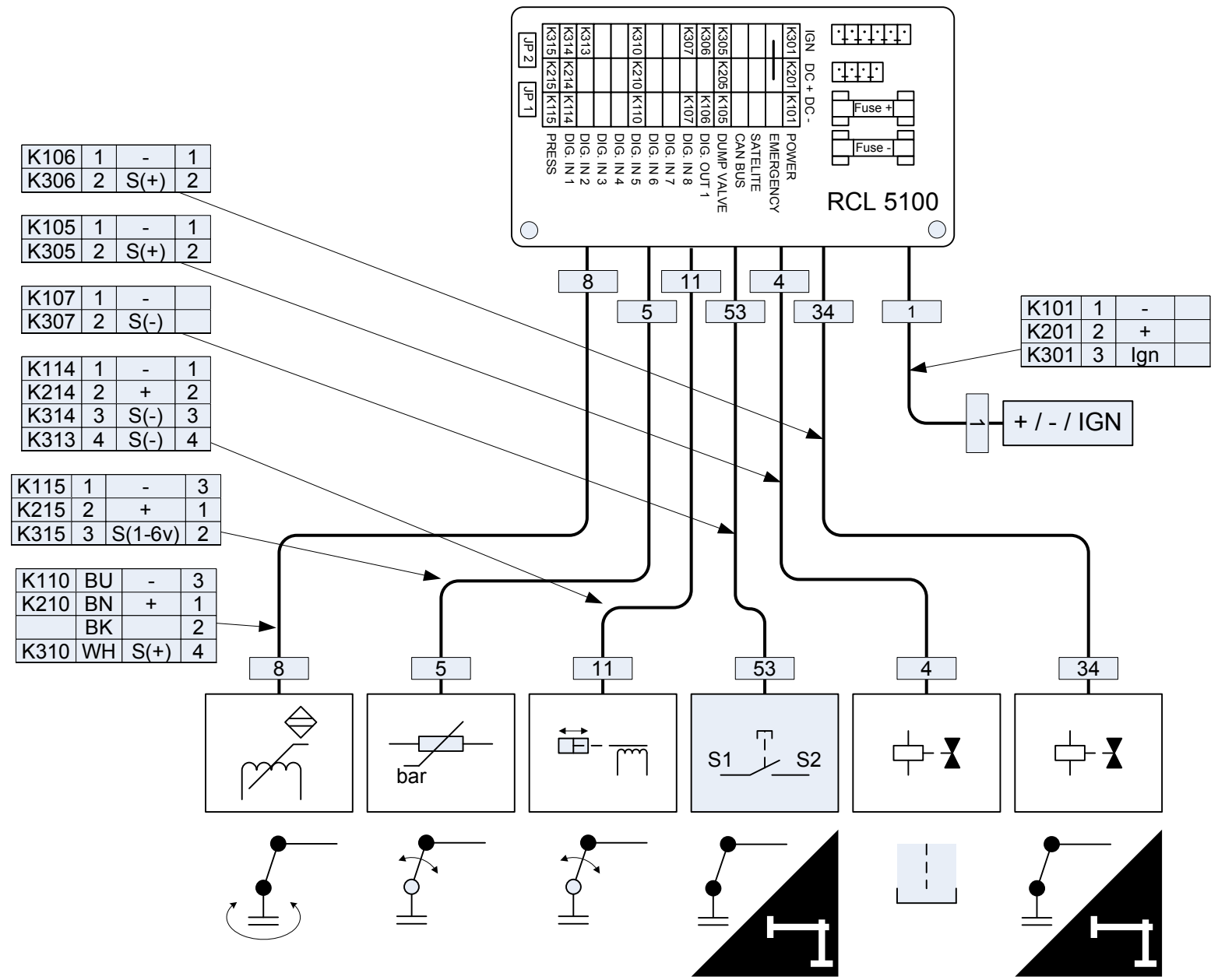
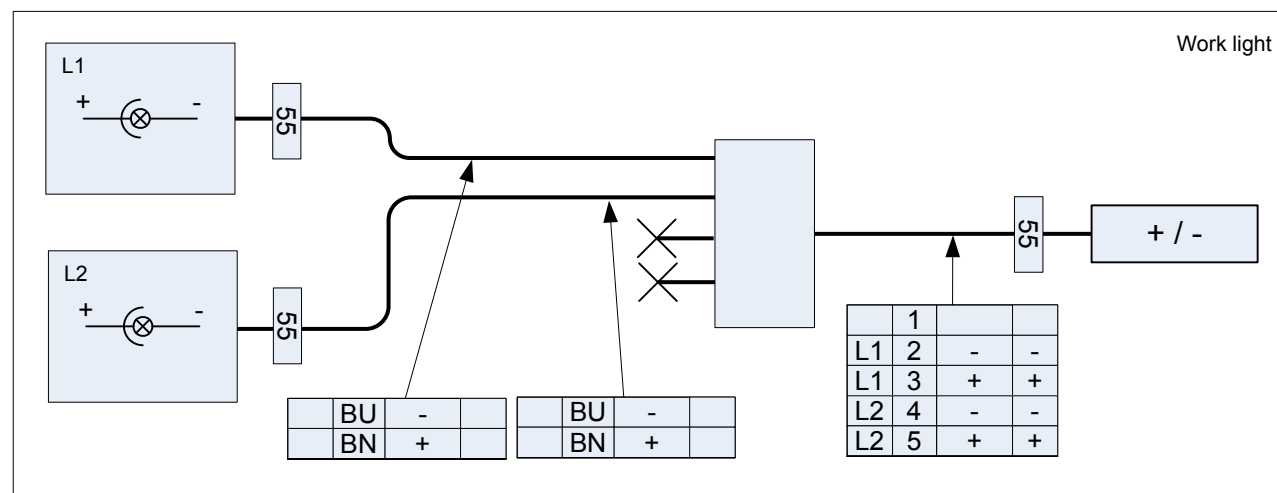
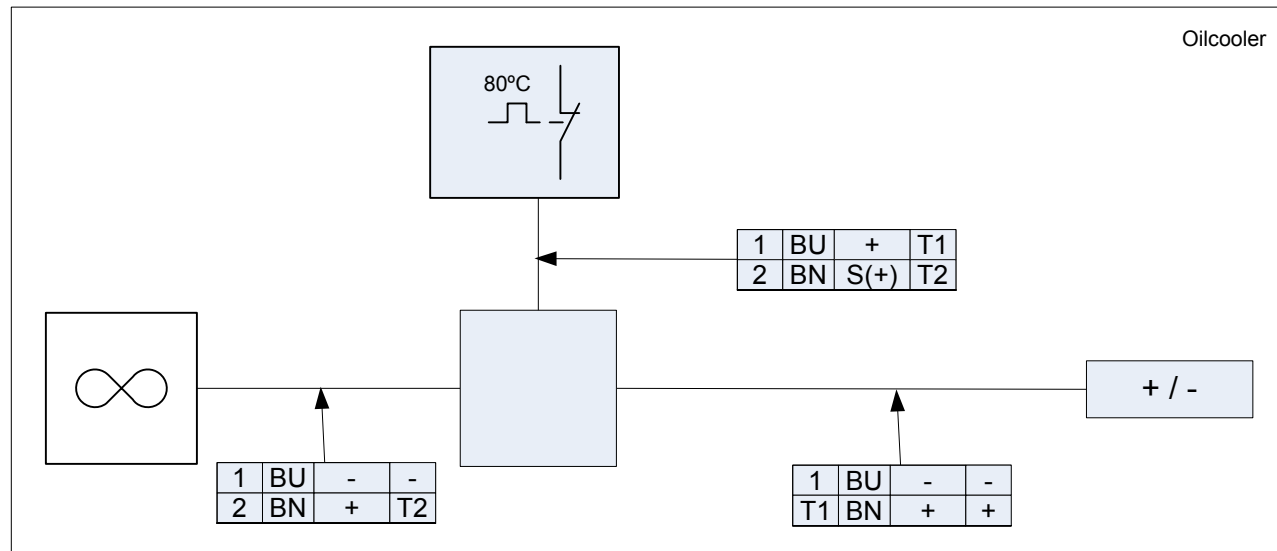

|           |            |       |                                 |  |            |  |            |  |
|-----------|------------|-------|---------------------------------|--|------------|--|------------|--|
| Ændringer |            |       | Produkt                         |  | Dato       |  | Målforhold |  |
| Nr.       | Dato       | Sign. | RCL 5100                        |  | 29.03.2006 |  |            |  |
| A         | 29.03.2006 | PHH   | S1244-1444-1643 Z std           |  | Sign. PHH  |  |            |  |
|           |            |       | Emne                            |  | Erstatter  |  |            |  |
|           |            |       | Højbjerg Maskinfabrik a/s       |  | Tegn nr.   |  | 70 20 039  |  |
|           |            |       | Oddervej 200 - DK-8270 Højbjerg |  | Erstat af  |  |            |  |

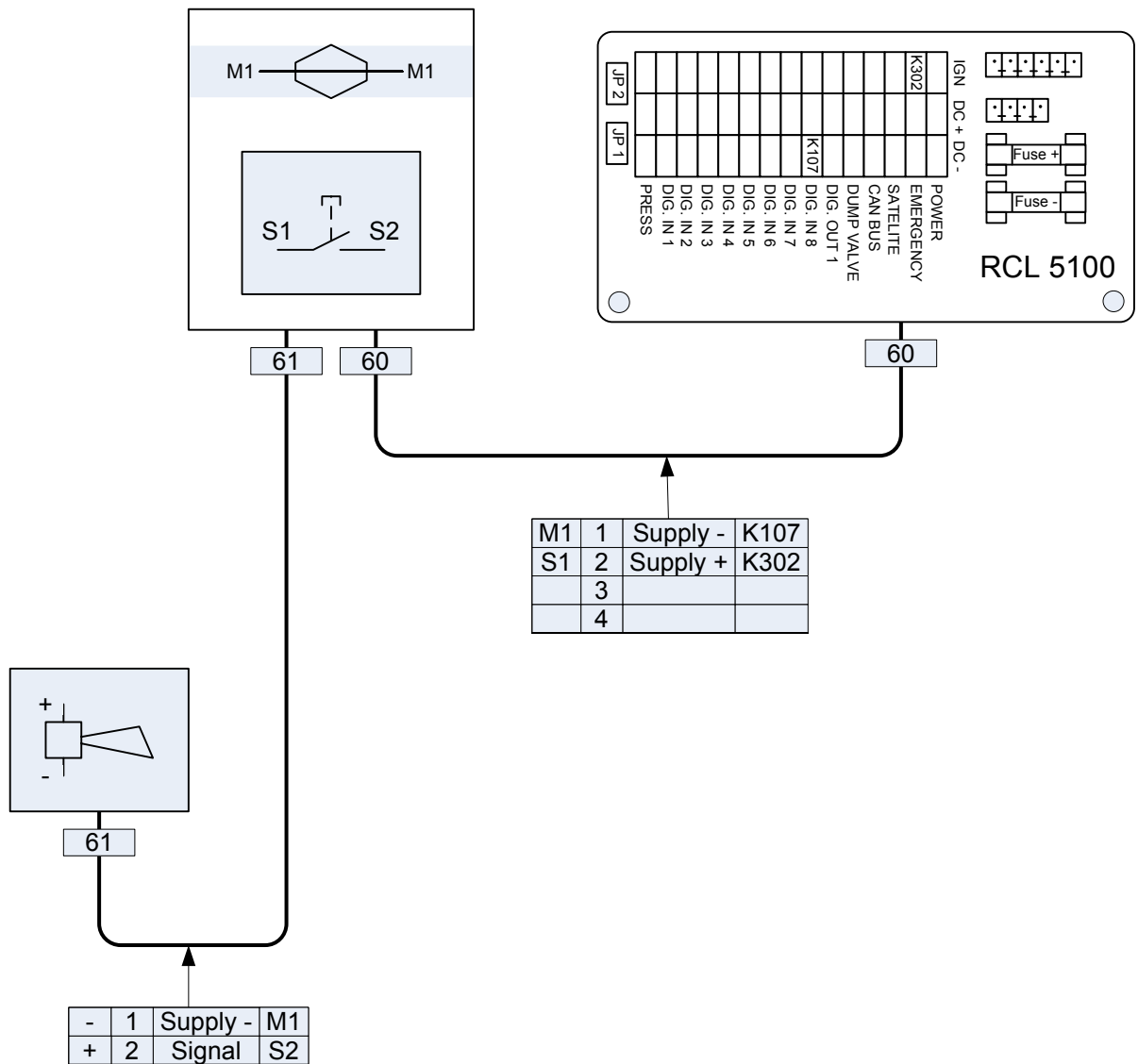

|           |            |       |  |  |            |  |            |  |
|-----------|------------|-------|--|--|------------|--|------------|--|
| Ændringer |            |       | Produkt  |  | Dato       |  | Målforhold |  |
| Nr.       | Dato       | Sign. | RCL 5100   |  | 30.09.2005 |  |            |  |
| A         | 30.09.2005 | JMO   |  |  | Sign.      |  | JMO        |  |
| B         | 01.05.2006 | BWK   | Emne   |  | Erstatter  |  |            |  |
|           |            |       | Horn, standard   |  | Tegn nr.   |  | 70 20 041  |  |
|           |            |       |  <b>Højbjerg Maskinfabrik <math>\frac{a}{s}</math></b><br>Oddervej 200 - DK-8270 Højbjerg |  | Erstat af  |  |            |  |



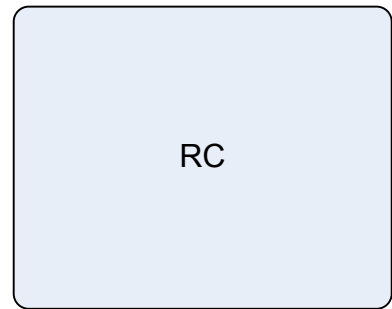
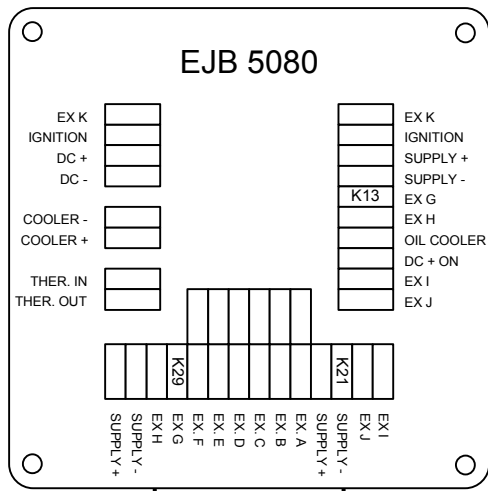

60

EX

EX

|     |   |        |   |
|-----|---|--------|---|
|     | 1 |        |   |
|     | 2 |        |   |
|     | 3 |        |   |
|     | 4 |        |   |
|     | 5 |        |   |
|     | 6 |        |   |
| K29 | 7 | Signal | * |

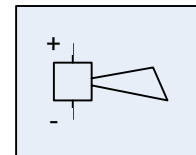

60

|     |   |          |   |
|-----|---|----------|---|
| K13 | 1 | Signal   | + |
| K21 | 2 | Supply - | - |

| Ændringer |            |       |
|-----------|------------|-------|
| Nr.       | Dato       | Sign. |
| A         | 15.05.2003 | PHH   |
| B         | 30.09.2005 | JMO   |
| C         | 01.05.2006 | BWK   |
|           |            |       |
|           |            |       |
|           |            |       |

Produkt **RCL 5100**

Emne **Horn, IRC, RC 400**



**Højbjerg Maskinfabrik  $\frac{a}{s}$**   
Oddervej 200 - DK-8270 Højbjerg

|           |                   |                  |
|-----------|-------------------|------------------|
| Dato      | <b>15.05.2003</b> | Målforhold       |
| Sign.     | <b>PHH</b>        |                  |
| Erstatter |                   |                  |
| Tegn nr.  |                   | <b>70 20 042</b> |
| Erstat af |                   |                  |

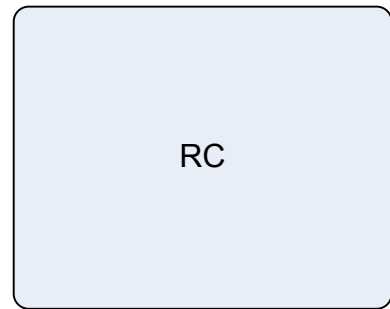
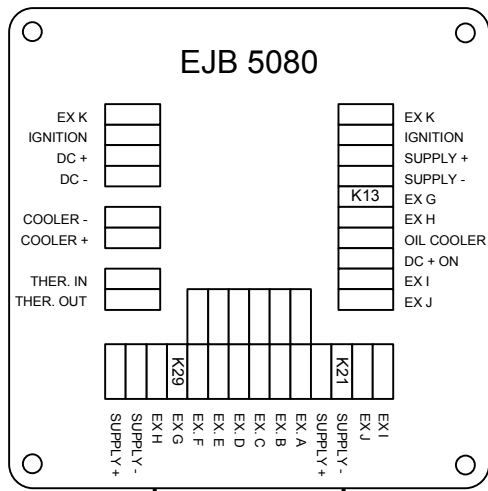

60

EX

EX

|     |      |        |   |
|-----|------|--------|---|
|     | BK   |        |   |
|     | BN   |        |   |
|     | RD   |        |   |
|     | YE   |        |   |
|     | GN   |        |   |
|     | VT   |        |   |
| K29 | GY   | Signal | * |
|     | WH   |        |   |
|     | PK   |        |   |
|     | RDBU |        |   |
|     | GYPK |        |   |

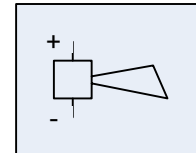

60

|     |   |          |   |
|-----|---|----------|---|
| K13 | 1 | Signal   | + |
| K21 | 2 | Supply - | - |

| Ændringer |            |      |
|-----------|------------|------|
| Nr.       | Dato       | Sign |
| A         | 15.05.2003 | PHH  |
| B         | 30.09.2005 | JMO  |
| C         | 01.05.2006 | BWK  |
|           |            |      |
|           |            |      |
|           |            |      |

Produkt **RCL 5100**

Emne **Horn, IRC, BMS 1**



**Højbjerg Maskinfabrik**  $\frac{a}{s}$

Oddervej 200 - DK-8270 Højbjerg

|           |                   |                  |
|-----------|-------------------|------------------|
| Dato      | <b>15.05.2003</b> | Målforshold      |
| Sign.     | <b>PHH</b>        |                  |
| Erstatter |                   | <b>70 20 043</b> |
| Tegn nr.  |                   |                  |
| Erstat af |                   |                  |

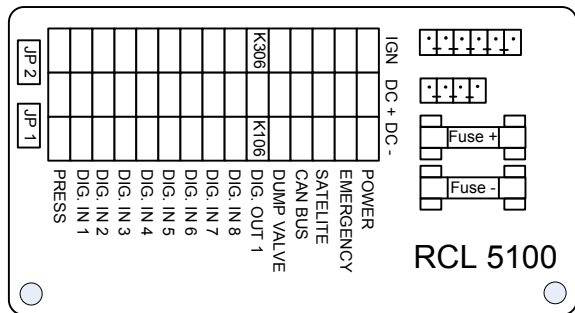

|      |   |          |   |
|------|---|----------|---|
| K306 | 1 | Signal   | + |
| K106 | 2 | Supply - | - |

| Ændringer |            |      |
|-----------|------------|------|
| Nr.       | Dato       | Sign |
| A         | 02.05.2006 | BWK  |
|           |            |      |
|           |            |      |
|           |            |      |
|           |            |      |

Produkt  
**RCL 5100**

Emne  
**EI-omskifter til støtteben**



**Højbjerg Maskinfabrik  $\frac{a}{s}$**   
Oddervej 200 - DK-8270 Højbjerg

|           |                  |            |
|-----------|------------------|------------|
| Dato      | 02.05.2006       | Målforhold |
| Sign.     | BWK              |            |
| Erstatter |                  |            |
| Tegn nr.  | <b>70 20 044</b> |            |
| Erstat af |                  |            |